

HEAVY-DUTY CLUTCH CATALOG



ROAD CHOICE



We are committed to keeping trucks on the road and moving forward by providing quality parts to all who repair heavy-duty vehicles.

CONFIDENCE.
COVERAGE.
COMMITMENT.

TABLE OF CONTENTS

BENEFITS AND FEATURES OF OUR CLUTCHES

Road Choice 15.5" Clutch Assembly	5
Cryogenically Treated Disc Springs	6
Determining the Proper Clutch for Your Vehicle	7
Road Choice Clutch Selection Guide	8

MEDIUM-DUTY TRUCK CLUTCHES

14" Stamped Steel Clutches	9
14" x 1.75"	10
14" x 2"	11

HEAVY-DUTY TRUCK CLUTCHES

14" x 1.75"	12
14" x 2"	13
15.5" x 2", 8 Spring	14
15.5" x 2", 10 Spring	15
15.5" x 2", 7 and 9 Spring	16

SELF-ADJUSTING CLUTCHES

Self-Adjusting	17-18
AMT	19

FLYWHEELS

Caterpillar	20
Cummins	21-22
Detroit	23
Ford-Sterling	23
Mack	24
Navistar	25
Volvo	26

CLUTCH ACCESSORIES

Kits	28-30
------------	-------

CLUTCH INSTALLATION

MANUAL-ADJUSTING CLUTCHES

Guidelines	31-35
Setup Procedure	36-37
Troubleshooting and Diagnostics	38

SELF-ADJUSTING CLUTCHES

Installation Guidelines	39-42
Setup Procedure	43-44
Troubleshooting and Diagnostics	45
Reset Procedure	46

MAINTENANCE TIPS

ENGINE HORSEPOWER AND TORQUE RATINGS

CROSS-REFERENCE

TOP 10 SELLING

FEATURES AND BENEFITS

NO CORES TO HANDLE

Only new parts and assemblies are used.

THE ROAD CHOICE® EZ SERIES CLUTCH

Requires up to 25 percent less pedal effort than an equivalent standard unit. A number of design and process patents contribute to a soft pedal.

DISC SPRINGS

Every Road Choice clutch unit is shipped with discs that contain chrome-silicon, valve-quality steel disc springs. Each spring is cryogenically treated using a patented process that virtually eliminates spring failure, which can increase clutch life.

FRICTION MATERIAL

Road Choice offers asbestos-free woven organic and sintered copper materials. The high-friction properties of these materials result in low wear and high reliability. Test results show a high coefficient of friction (COF), which increases torque capacity.

FIBER SPACER

Shipped free of charge in every new Road Choice clutch unit, this spacer is essential to achieving brake squeeze when the flywheel has been resurfaced.

STATE-OF-THE-ART ASSEMBLY

Every Road Choice clutch unit is shipped as a “serialized” matched unit and digitally recorded to the specific serial number.

CAST COVER REPLACEMENT

Road Choice offers a cast cover replacement for its medium-duty clutch.

MADE IN THE USA

Road Choice clutch units are manufactured and assembled in the United States.



WARRANTY

All Road Choice clutch units offer

24 months and unlimited mileage

15.5" CLUTCH ASSEMBLY

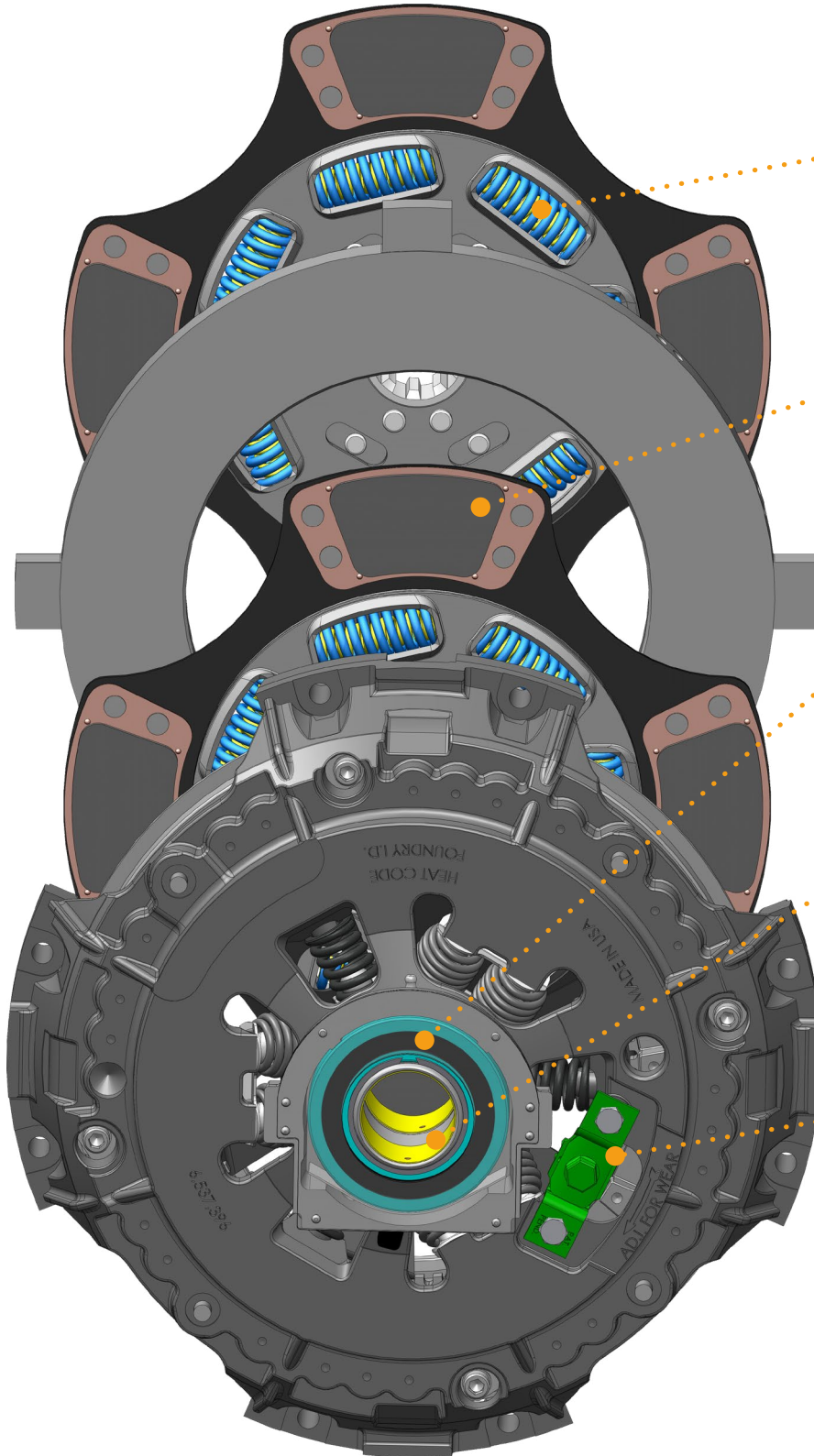

Patented cryogenically treated springs virtually eliminate disc spring failures

Premium copper-based friction material

Sealed, permanently lubed release bearing is standard on all Road Choice assemblies

Bushings are pressed, then crimped into sleeve, promoting longer bushing life

Patented self-locking adjuster, no lock to remove or depress – just turn to adjust

CRYOGENICALLY TREATED DISC SPRINGS

A PATENTED PROCESS

One of the many selling features of Road Choice EZ Series clutch units is an exclusive patented process of cryo treating the disc springs. Unlike most clutch manufacturers and rebuilders, we use a chrome-silicon, valve-quality spring. With the combination of higher quality steel and cryo treating, disc spring failure is virtually eliminated.

The cryogenic process involves taking springs to -300°F . The temperature cycle is regulated by a computer-controlled flow of nitrogen into the chamber where the parts are placed. After the disc springs are returned to room temperature, they are placed in a tempering furnace and tempered to a setting of $+300^{\circ}\text{F}$ - 400°F .

A variety of improvements are gained, such as stress relief, wear resistance and fatigue life. Testing reflects an increase in spring life from two to five times that of an untreated spring.

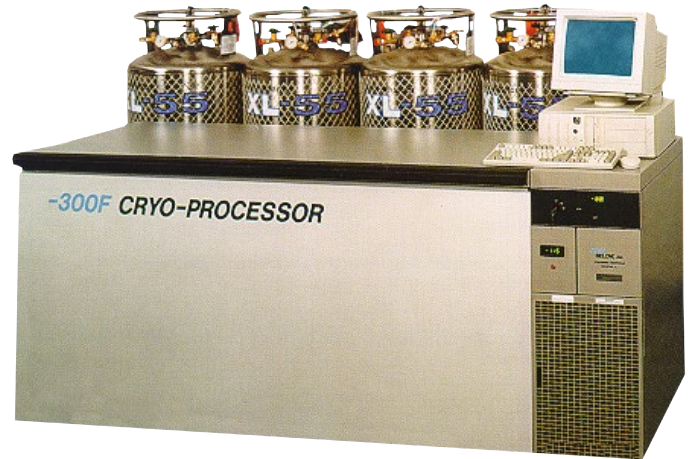

THE THEORY

The cryogenic process most commonly applies to heat-treated steels, which are stronger and harder. Heat-treating is a process of heating the steel, quenching it in oil or water, and draw tempering it. Each spring is cryogenically treated using a patented process that virtually eliminates spring failure, which can increase clutch life. However, the martensite becomes too brittle in this state for most heat-treated steels. By elevating the temperature again, but to a lower temperature than it was originally tempered, the martensite becomes less brittle but also stronger and harder. The "retained" austenite may still make up more than 5 percent of the quenched and tempered structure in the steel. By cryogenically treating the steel, the austenite is transformed into martensite so that the structure is 100 percent martensite. It is believed the cryogenic process causes atoms to diffuse or migrate and fill voids, creating a more homogeneous grain structure with improved properties.

This process is also used for all tools such as dies, punches, drills, taps, broaches and cutting inserts. Depending on the parts being treated, a 50 percent to 300 percent increase in performance life is achieved.

DETERMINING THE PROPER CLUTCH FOR YOUR VEHICLE

1. Determine the size of the clutch (14" or 15.5").
2. If 15.5", then measure the center flywheel opening (Dimension A* in the illustration).
Approximate flywheel sizes: 7", 8.5" or 10"
 - A. If flywheel bore is 7", ONLY use an 8 spring disc.
 - B. If flywheel bore is 8.5", use a 10 spring disc.
 - C. If flywheel bore is 10", use a 7 spring or a 9 spring (Mack*).
 - D. If you have a 10" flywheel bore, DO NOT USE ORGANIC FACING. The facing I.D. will extend into the flywheel bore opening and will not have full facing contact.
3. Determine engine torque at current settings (See Page 46, Torque Chart).
4. Identify linkage type: mechanical or hydraulic.
Note: Manual-adjust clutches are not recommended for hydraulic release systems.

*Also fits various Volvo models. Check manufacturer's specifications.

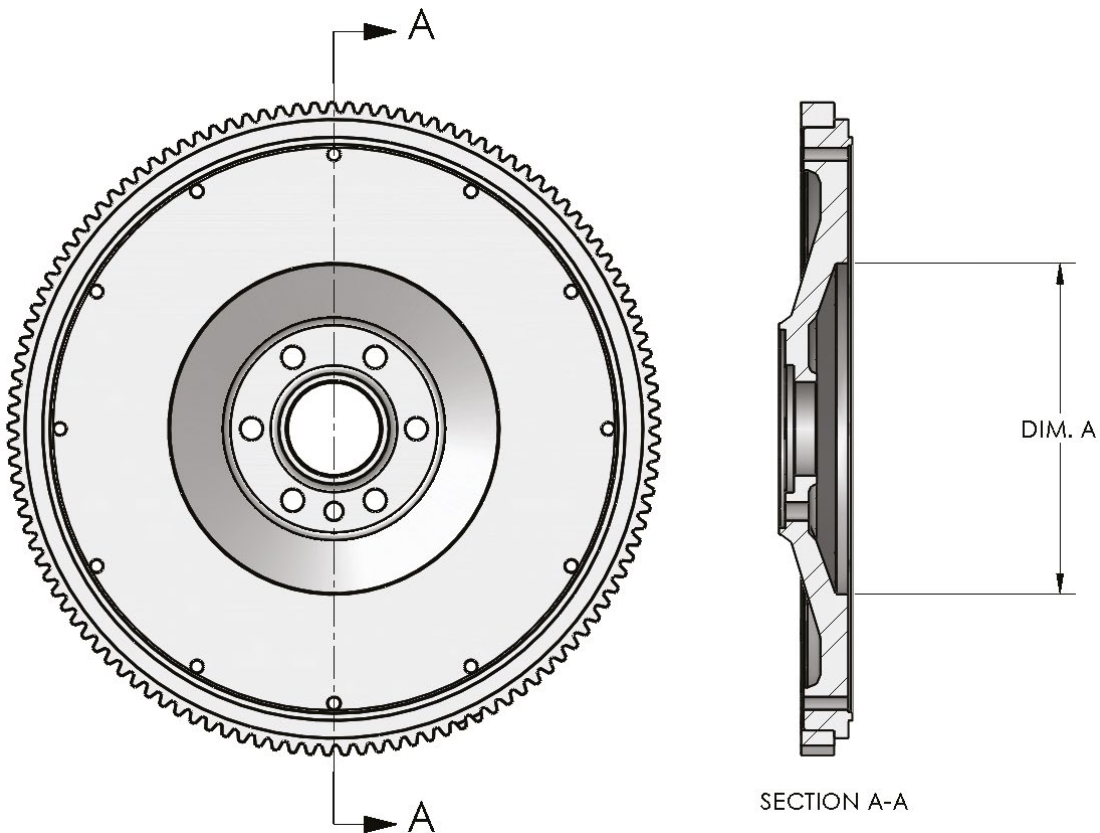

CLUTCH SELECTION GUIDE

CLUTCH MODELS TO USE BY FLYWHEEL BORE SIZE

14" CLUTCHES

All 14" clutches use 8 spring disc assemblies and can be used only with 7" flywheel bore size.

15.5" CLUTCHES

Disc types will vary and are designed to be used with a specific flywheel bore size.

Shown below are the Road Choice EZ and STANDARD clutch models designed for each bore size.

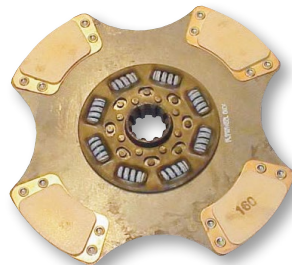
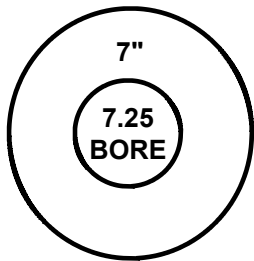

8 SPRING DISC

ROAD CHOICE® EZ CLUTCH CHOICES
CLU20839181

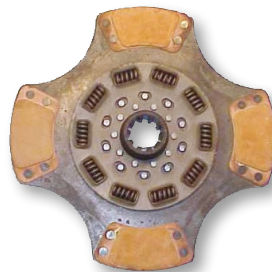
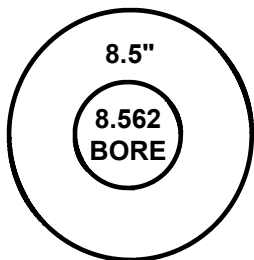

10 SPRING DISC

ROAD CHOICE® EZ CLUTCH CHOICES
CLU20839174
CLU20839193
CLU20839193H

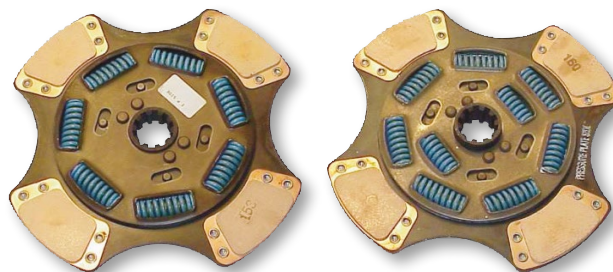
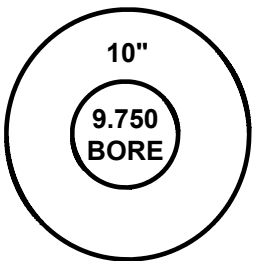

7 & 9 SPRING DISC

ROAD CHOICE® EZ CLUTCH CHOICES
CLU20892582
CLU20892582H
CLU20892532H
CLU20893551 (Mack Only)*
CLU20893551H (Mack Only)*

ROAD CHOICE® SELF-ADJUSTING CLUTCH CHOICES
CLU20992582
CLU20992582H
CLU20993551
CLU20993551H

*Also fits various Volvo models. Check manufacturer's specifications. Manual-adjust clutches are not recommended for hydraulic release systems.

MEDIUM-DUTY TRUCK CLUTCHES

14" STAMPED STEEL CLUTCHES



PART NUMBER	TORQUE	PLATE LD	DISC STYLE
CLU10723710	860	2400	1.75", 8 Spring 3 Pad
CLU10734212	860	2400	2", 8 Spring 3 Pad

14" MEDIUM-DUTY TRUCK CLUTCHES

HEAVY-DUTY CLUTCH FOR MEDIUM-DUTY TRUCK

14" x 1.75" For 14" Flat Flywheel, H.D. Cast Version of Stamped Steel

DUAL DISC



PART NUMBER	TORQUE	PLATE LD	DISC STYLE	PEDAL	ADJ
CLU1072378	900	2800	Ceramic 8 Spring 3 Pad Co - Ft	EZ	EZ

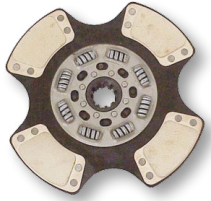

PART NUMBER	TORQUE	PLATE LD	DISC STYLE	PEDAL	ADJ
CLU1072374	950	2800	Ceramic 8 Spring 4 Pad Co - Ft	EZ	EZ

SINGLE DISC

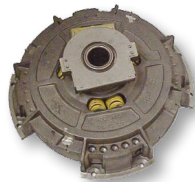

PART NUMBER	TORQUE	PLATE LD	DISC STYLE	PEDAL	ADJ
CLU1076835	620	2800	Ceramic 8 Spring 3 Pad Co - Ft	EZ	EZ

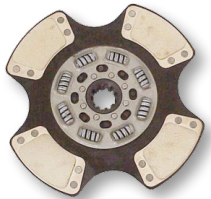

PART NUMBER	TORQUE	PLATE LD	DISC STYLE	PEDAL	ADJ
CLU1076834	680	2800	Ceramic 8 Spring 4 Pad Co - Ft	EZ	EZ

Note: These clutches are not adjusted for synchronized transmissions.

14" MEDIUM-DUTY TRUCK CLUTCHES

HEAVY-DUTY CLUTCH FOR MEDIUM-DUTY TRUCK

14" x 2" For 14" Flat Flywheel, H.D. Cast Version of Stamped Steel

DUAL DISC



PART NUMBER	TORQUE	PLATE LD	DISC STYLE	PEDAL	ADJ
CLU1076862	900	2800	Ceramic 8 Spring 3 Pad Co - Ft	EZ	EZ

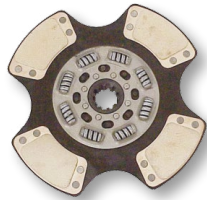

PART NUMBER	TORQUE	PLATE LD	DISC STYLE	PEDAL	ADJ
CLU1076864	950	2800	Ceramic 8 Spring 4 Pad Co - Ft	EZ	EZ

14" HEAVY-DUTY TRUCK CLUTCHES

14" X 1.75" RECESS (POT) FLYWHEEL

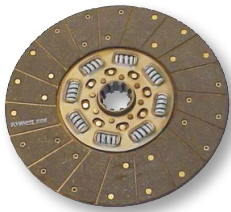
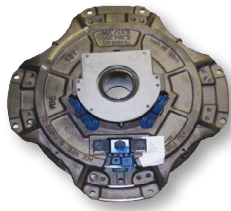

PART NUMBER	TORQUE	PLATE LD	DISC STYLE	PEDAL	ADJ
CLU10805060	1150	3600	Organic 8 Spring Co - Ft	EZ	DUAL
CLU10703582	1150	3600	Organic 8 Spring Co - Ft	STD	STD

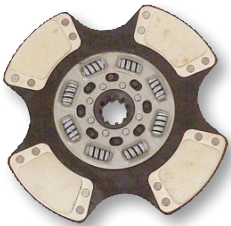

PART NUMBER	TORQUE	PLATE LD	DISC STYLE	PEDAL	ADJ
CLU10806359	1400	3600	Ceramic 8 Spring 4 Pad Co - Ft	EZ	DUAL
CLU10706359	1400	3600	Ceramic 8 Spring 4 Pad Co - Ft	STD	STD

VITON® SEALED BEARINGS

Made With the High Performance Elastomer Viton®

EXCELLENT RESISTANCE TO:

- Petrochemicals/fluids
- Extreme temperatures
- Now a minimum requirement by all OEMs



AB197V
6306

AB197SV
6306-S
(Mack Application)



14" HEAVY-DUTY TRUCK CLUTCHES

14" X 2" RECESS (POT) FLYWHEEL

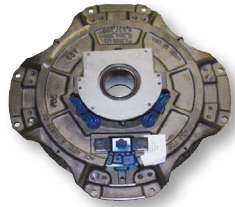

PART NUMBER	TORQUE	PLATE LD	DISC STYLE	PEDAL	ADJ
CLU10703461	1250	3600	Ceramic 8 Spring 3 Pad Co - Ft	STD	STD

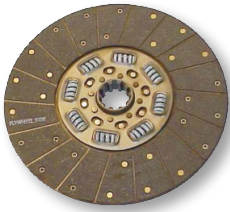

PART NUMBER	TORQUE	PLATE LD	DISC STYLE	PEDAL	ADJ
CLU10703482	1150	3600	Organic 8 Spring Co - Ft	STD	STD

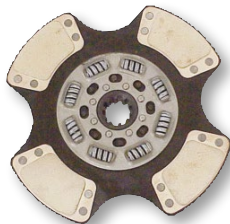

PART NUMBER	TORQUE	PLATE LD	DISC STYLE	PEDAL	ADJ	COMMENTS
CLU10805059	1400	3600	Ceramic 8 Spring 4 Pad Co - Ft	EZ	DUAL	Heavy-Duty Plate
CLU10705069	1400	3600	Ceramic 8 Spring 4 Pad Co - Ft	STD	STD	Standard Plate

15.5" HEAVY-DUTY TRUCK MANUAL-ADJUST CLUTCHES

15.5" X 2", 8 SPRING 7" FLYWHEEL BORE

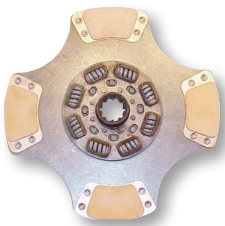

PART NUMBER	TORQUE	PLATE LD	DISC STYLE	PEDAL	ADJ
CLU20839181	1400	3600	Ceramic 8 Spring 4 Pad Co - Ft	EZ	DUAL

15.5" HEAVY-DUTY TRUCK MANUAL-ADJUST CLUTCHES

15.5" X 2", 10 SPRING 8.5" FLYWHEEL BORE

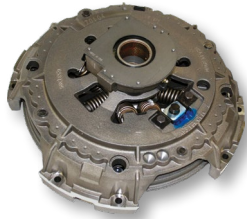

PART NUMBER	TORQUE	PLATE LD	DISC STYLE	PEDAL	ADJ
CLU20839174	1650	3600	Ceramic 10 Spring 4 Pad Co - Ft	EZ	DUAL
CLU20839193	1860	4000	Ceramic 10 Spring 4 Pad Co - Ft	EZ	DUAL

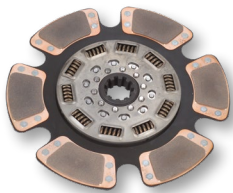

PART NUMBER	TORQUE	PLATE LD	DISC STYLE	PEDAL	ADJ
CLU20839193H	2050	4000	Ceramic 10 Spring 6 Pad Co - Ft	EZ	DUAL

15.5" HEAVY-DUTY TRUCK MANUAL-ADJUST CLUTCHES

15.5" X 2", 7 AND 9 SPRING 10" FLYWHEEL BORE

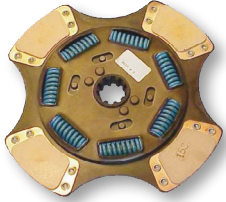
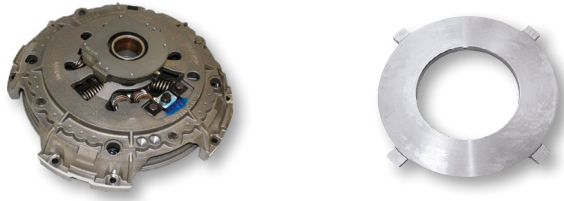

PART NUMBER	TORQUE	PLATE LD	DISC STYLE	PEDAL	ADJ
CLU20892582	1700	3600	Ceramic 7 Spring 4 Pad Co - Ft	EZ	DUAL

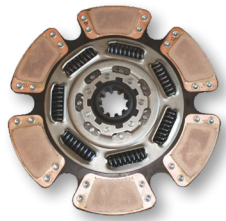

PART NUMBER	TORQUE	PLATE LD	DISC STYLE	PEDAL	ADJ
CLU20892582H	2050	4000	Ceramic 7 Spring 6 Pad Co - Ft	EZ	DUAL
CLU20892525	2050	4000	Ceramic 7 Spring 6 Pad Co - Ft	EZ	DUAL
CLU20892532H	2250	4500	Ceramic 7 Spring 6 Pad Co - Ft	EZ	DUAL

15.5" X 2" 9 SPRING 10" FLYWHEEL BORE

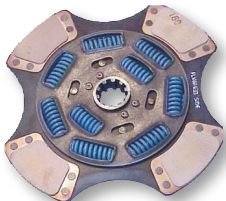

PART NUMBER	TORQUE	PLATE LD	DISC STYLE	PEDAL	ADJ	COMMENT
CLU20893551	1700	3600	Ceramic 9 Spring 4 Pad Co - Ft	EZ	DUAL	*Mack Only

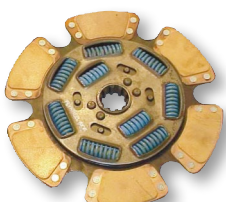

PART NUMBER	TORQUE	PLATE LD	DISC STYLE	PEDAL	ADJ	COMMENT
CLU20893551H	2050	4000	Ceramic 9 Spring 6 Pad Co - Ft	EZ	DUAL	*Mack Only

*Also fits various Volvo models. Check manufacturer's specifications.

HEAVY-DUTY SELF-ADJUST CLUTCHES

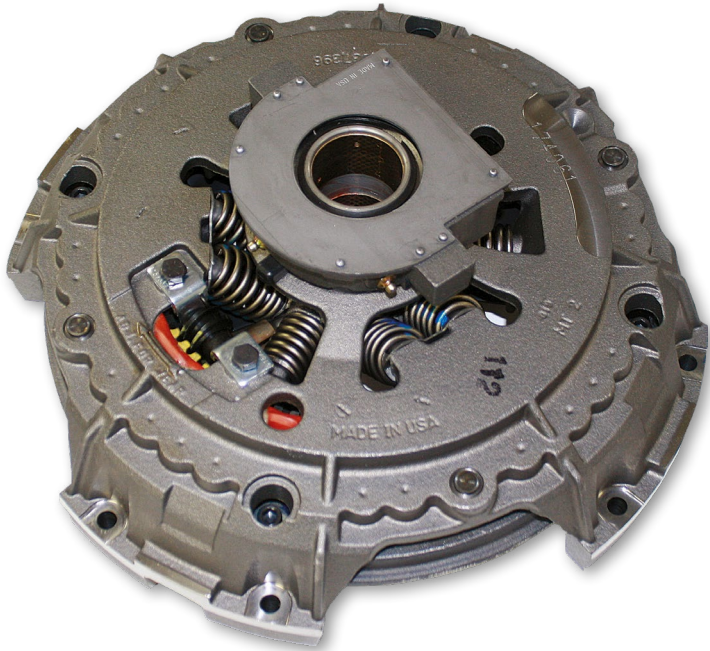

ROAD CHOICE® SELF-ADJUSTING CLUTCHES

Our self-adjusting clutches are technician-friendly. They utilize patented contamination prevention technology.

- Made in the United States
- All new – no cores
- 2-year warranty

ROBUST ADJUSTER DESIGN

- Positively engaged ratchet system
- 4-lug drive gear has the capability to deliver over 50 ft-lbs of torque to the adjusting ring
- Self-locking worm gear ensures responsive adjustment

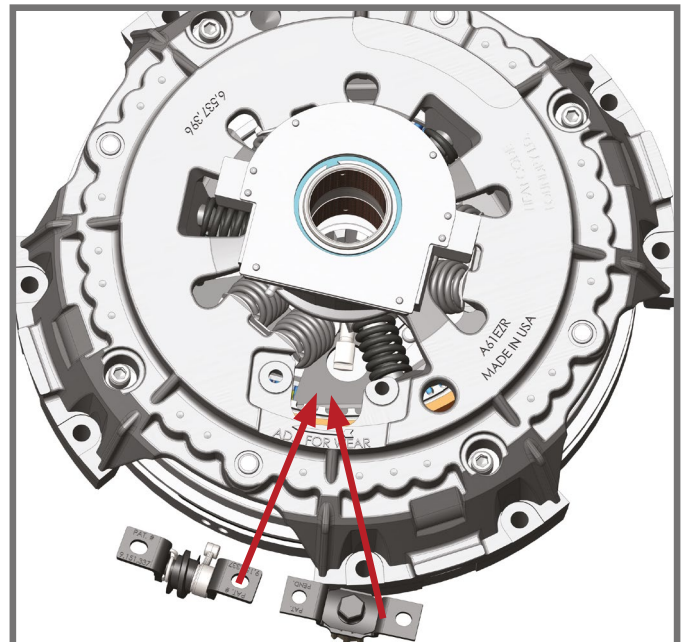

HEAVY-DUTY SELF-ADJUST CLUTCHES

PART NUMBER	DESCRIPTION	EATON CROSS-REFERENCE
CLU20992582	15.5" x 2", 4 Paddle, 7 Spring, 1700 Ft-Lbs	209701-82* 309701-82
CLU20992582H	15.5" x 2", 6 Paddle NVH,** 7 Spring, 2050 Ft-Lbs	209701-25* 309701-25
CLU20993551	15.5" x 2", 4 Paddle, 9 Spring, 1700 Ft-Lbs	209701-51* 309701-51
CLU20993551H	15.5" x 2", 6 Paddle, 9 Spring, 2050 Ft-Lbs	209701-92* 309701-98
CLU12200235A	15.5" x 2", 14 spline, 6 paddle, 7 spring NVH, 1850 Ft-Lbs	122002-35A
CLU12200342A	15.5" x 2", 14 spline, 6 paddle, 7 spring NVH, 2250 Ft-Lbs	122003-42A

*References to manufacturer's trade names and part numbers are for identification only.

**Noise Vibration Harshness

SERVICEABILITY

- No complicated reset procedure
- Resets with manual adjuster
- Same procedure as manual-adjust clutch

INSTALLATION

- No need to retrain technicians
- Same installation procedure as manual-adjust clutch

WILL NOT OVER ADJUST

- Not susceptible to outside forces (for example, backing into docks or hitting potholes during disengagement)

CONTAMINATION PREVENTION TECHNOLOGY

- Self-contained components in adjuster maintain optimal adjusting function
- Patented Actively Expanding Seal (AES) creates an industry-first anti-contamination enclosure
- Specialized lubrication ensures optimal adjustments throughout the life of the clutch

AMT SELF-ADJUST CLUTCHES

ROAD CHOICE® OFFERS A 430MM PUSH STYLE CLUTCH, with specially designed options for Freightliner DT-12 Trucks as well as Mack and Volvo Trucks. Advanced engineering ensures smooth engagement and seamless gear shifts, providing enhanced vehicle maneuverability and improved acceleration. Built to withstand heavy-duty applications, the 430MM Push Style Clutches boast exceptional wear resistance, reducing maintenance downtime and operating costs for our valued customers. The innovative design prioritizes driver comfort and safety, delivering precise pedal feel and reduced effort during operation. You can purchase confidently knowing our commitment to quality, and this product undergoes rigorous testing to exceed industry standards, offering our customers a reliable and superior clutch solution.



WARRANTY: Two-year/unlimited miles.

FREIGHTLINER PART NUMBER	DESCRIPTION	FREIGHTLINER CROSS-REFERENCE	EATON CROSS-REFERENCE
CLU4489DT12	430 mm, 6 spring, 2400 ft-lbs, 18 splines	A02-82500-001 A02-14027-008 A02-14135-000	K-4489CL

PART NUMBER	DESCRIPTION	MACK CROSS-REFERENCE	VOLVO CROSS-REFERENCE
CLU1044611	430 mm Push type, 6 spring, 1850 ft-lbs, 24 splines	24670819*	24670819**

* Please note that the previous part number, 85022395, has been superseded to 24670819.

** Please note that the previous part number, 85002560, has been superseded to 24670819.

FEATURES AND BENEFITS

- 430mm push self-adjusting diaphragm
- Stamped steel clutch
- Organic facing
- Smooth engagement
- 100% new components
- Pre-damper
- No maintenance required

FLYWHEELS - CATERPILLAR

CATERPILLAR	PART NUMBER	DESCRIPTION	APPLICATION
	FLY4P4797	15" Flat Flywheel 10" Bore 12 Mounting Bolt Holes Use 7 Spring Clutch Bearing (6306) 20" Ring Gear 113 Teeth Ring Gear #4N2514	CAT 3406/3406E
	FLY9Y9311	14" Flat Flywheel 7" Bore 10 Mounting Bolt Holes Use With 8 Spring Clutch Bearing (6305) Or (6206) Ring Gear #9I8113 Ring Gear #968113 17" Ring Gear 134 Teeth	CAT 3208
	FLY1265875	14" Flat Flywheel 7" Bore 8 Mounting Bolt Holes 1 Dowel Pinhole Bearing (6206) 17" Ring Gear 134 Teeth Ring Gear #7W5095	CAT 3116/3126
	FLY4P8515	15" Flat Flywheel 10" Bore 8 Mounting Bolt Holes Use 7 Spring Clutch Bearing (6306) 20" Ring Gear 113 Teeth	CAT 2176. C10, C12
	FLY2569653	15" Flat Flywheel 10" Bore 12 Mounting Bolts Use 7 Spring Clutch Bearing (6306) 20" Ring Gear 113 Teeth	CAT C15, C16, C18

FLYWHEELS - CUMMINS

CUMMINS	PART NUMBER	DESCRIPTION	APPLICATION
	FLY3016495	14" Pot Flywheel 7" Bore 6 Mounting Bolt Holes *Use 8 Spring Clutch Bearing (6306) Drive Pins Not Included 17" Ring Gear 103 Teeth Ring Gear #4797	Cummins NT855 Small CAM Big CAM
	FLY3680922	15" Flat Flywheel 10" Bore 12 Mounting Bolts *Use 7 Spring Clutch Bearing (6306) 20" Ring Gear 113 Teeth	Cummins ISX
	FLY3042787	14" Pot Flywheel 7" Bore 8 Mounting Bolt Holes *Use 8 Spring Clutch Bearing (6306) Drive Pins Not Includ- ed 17" Ring Gear 103 Teeth Ring Gear #4797	Cummins L10/M11

FLYWHEELS - CUMMINS

CUMMINS	PART NUMBER	DESCRIPTION	APPLICATION
	FLY3071535	5" Flat Flywheel 10" Bore 6 Mounting Bolt Holes *Use 7 Spring Clutch Bearing (6306) 17" Ring Gear 103 Teeth Ring Gear #4797	Cummins NT855 N14
	FLY3071615	15" Flat Flywheel 10" Bore 8 Mounting Bolt Holes *Use 7 Spring Clutch Bearing (6306) Ring Gear #4797 17" Ring Gear 103 Teeth	Cummins M11
	FLY3921263	114" Flywheel 7" Bore 8 Mounting Bolt Holes *Use 8 Spring Clutch Bearing (6206) Ring Gear #3903309 173 Teeth	Cummins L10/M11





FLYWHEELS - DETROIT/ FORD-STERLING

DETROIT	PART NUMBER	DESCRIPTION	APPLICATION
	FLY23509709	15" Flat Flywheel 10" Bore 12 Mounting Bolt Holes *Use 7 Spring Clutch Bearing (6306) 20" Ring Gear 118 Teeth Ring Gear #5166664	Detroit Series 60
	FLY23514177	15" Flat Flywheel 10" Bore 12 Mounting Bolt Holes *Use 7 Spring Clutch Bearing (6306) 118 Teeth Ring Gear #5166664	Detroit 60 Lightweight
	FLY8922126	14" Flywheel 7" Bore 8 Mounting Bolt Holes *Use 8 Spring Clutch Bearing (6205) 17" Ring Gear 138 Teeth Ring Gear #5116302	Detroit 8.2
FORD-STERLING	PART NUMBER	DESCRIPTION	APPLICATION
	FLYE7HZ6375A	14" Flat Flywheel 7" Bore 8 Mounting Bolt Holes *Use 8 Spring Clutch Bearing (6206) 17" Ring Gear 138 Teeth Ring Gear #E6HZ6384A	Ford 6.6 & 7.8



FLYWHEELS - MACK

MACK	PART NUMBER	DESCRIPTION	APPLICATION
	FLY530GB3142	15" Flat Flywheel 10" Bore 20" Ring Gear 118 Teeth *Use 9 Spring Clutch Bearing (6306M) Ring Gear #673GB222	Mack 675 & 676
	FLY530GB3145BM	15" Flat Flywheel 10" Bore Dowel Hole Timing Mark 6 Metric Bolt Holes *Use 9 Spring Clutch Bearing (6306M) 20" Ring Gear 118 Teeth Ring Gear #673GB222	Mack E7
	FLY530GB3170	15" Flat Flywheel 10" Bore Dowel Hole Timing Mark 6 Metric Bolt Holes *Use 9 Spring Clutch Bearing (6306M) 20" Ring Gear 117 Teeth Ring Gear #673GB35	Mack E7 E-Tech Series

FLYWHEELS - NAVISTAR

NAVISTAR	PART NUMBER	DESCRIPTION	APPLICATION
	FLY1809144C91	14" Flat Flywheel 7" Bore 9 Mounting Bolt Holes *Use 8 Spring Clutch Bearing (6205) 17" Ring Gear 137 Teeth Ring Gear #1800777C1	Navistar 7.3 International 6.9 International
	FLY1810855C93	14" Flat Flywheel 7" Bore 8 Mounting Bolt Holes *Use 8 Spring Clutch Bearing (6205) 17" Ring Gear 138 Teeth Ring Gear #1815440C1	Navistar DT466
	FLY1818214C9	14" Flat Flywheel 7" Bore 10 Mounting Bolt Holes *Use 8 Spring Clutch Bearing (6206) or (6305) 17" Ring Gear 138 Teeth Ring Gear #1800777C1	Navistar 7.3 International
	FLY1821915C91	14" Flat Flywheel 7" Bore 12 Mounting Bolt Holes *Use 8 Spring Clutch Bearing (6206) or (6305) 17" Ring Gear 138 Teeth Ring Gear #1815440C1	Navistar DT466E

FLYWHEELS - VOLVO

VOLVO	PART NUMBER	DESCRIPTION	APPLICATION
	FLY20790714	15" Flat Flywheel 10" Bore 12 Mounting Bolt Holes *Use 7 Spring Clutch Bearing (6306) 153 Teeth Ring Gear #20711957	Volvo VED 11
	FLY20730056	15" Flat Flywheel 10" Bore 14 Mounting Bolt Holes *Use 7 Spring Clutch Bearing (6306) 153 Teeth Ring Gear #20711957	Volvo VED 12

CLUTCH ACCESSORIES

PART NUMBER	REFERENCE	DESCRIPTION
CLA274C6	274C-6	Drive Pin 14" Flywheel (6 per Bag)
CLA175CB		1.75" Clutch Brake (1 pc)
CLA175S		1.75" Fiber Spacer (6 per Bag)
CLA200S		2" Fiber Spacer (6 per Bag)
CLA127175	127175	1.75" Hinge Clutch Brake
CLA1272005		2" Oversized Hinge Clutch Brake
CLA127200		2" Hinge Clutch Brake
CLA125300	125300	EZ Adjuster
CLA127740	127740	1.75" Torque-Limiting Brake
CLA127760	127760	2" Torque-Limiting Brake
CLA6205	6205-2RS	Pilot Bearing (Rubber Sealed)
CLA6205M	6205-2RSNR	Pilot Bearing (Rubber Sealed for Mack)
CLA6206	6206-2RS	Pilot Bearing
CLA6305	6305-2RS	Pilot Bearing
CLA6306	6306-2RS	Pilot Bearing (Rubber Sealed)
CLA6306M	6306-2RSNR	Pilot Bearing (Rubber Sealed for Mack)
CLA6306V	6306-2VS	Pilot Bearing (Viton® Sealed)
CLA6306VM	6306-SN	Pilot Bearing (Viton® Sealed for Mack)
CLA12815	12815	Shaft Bushing (4 per Bag)
CLA105C137	105C-137	Release Fork
CLAFG100		Flywheel Gauge
CLACATLG		Clutch Adjusting Tool
CLATK200		Clutch Installation Tool Kit
CLAS1659	S-1659	Input Shaft
CLAS2822	S-2822	Input Shaft

ALIGNMENT

PART NUMBER	REFERENCE	DESCRIPTION
CLAAT150	OTC5379	1.50" x 10" Spline 1.180 Pilot
CLAAT175	OTC5380	1.75" x 10" Spline 1.180 Pilot
CLAAT175A	OTC5410	1.75" x 10" Spline .980 Pilot
CLAAT175X1	OTC5411	1.75" x 10" Spline 1.0 Pilot
CLAAT200	OTC5381	2.00" x 10" Spline 1.180 Pilot

INSTALLATION KITS

PART NUMBER	REFERENCE	DESCRIPTION
CLAK2468	RT Series	Major Install Kit with Torque-Limiting Clutch Brake
CLAK2468B	RT Series	Major Install Kit with Hinged Clutch Brake
CLAK3600	FR Series	Major Install Kit with Torque-Limiting Clutch Brake
CLAK3600B	FR Series	Major Install Kit with Hinged Clutch Brake
CLAK3762	RT Severe-Duty	Major Install Kit with Torque-Limiting Clutch Brake
CLAK3762B	RT Severe-Duty	Major Install Kit with Hinged Clutch Brake
CLAK2175	1.75"	Minor Install Kit with Torque-Limiting Clutch Brake
CLAK2200	2"	Minor Install Kit with Torque-Limiting Clutch Brake
CLAK2201	2"	Minor Install Kit with Hinged Clutch Brake



CLA274C6
Drive Pin



CLA105C137
Release Fork



CLA125300
Spring Adjuster



CLA127740, CLA127760
Torque-Limiting Clutch Brake



CLA127200, CLA127175, CLA1272005
Quick Change Hinge Brake



CLA6506V
Pilot Bearing

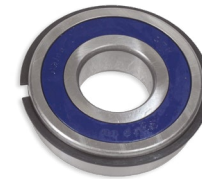

CLA6306VM
Pilot Bearing



CLAAT150, CLAAT175, CLAAT175A, CLAAT200, CLAAT175X1
Alignment Tool



CLACATLG
Clutch Adjusting Tool



CLA175S, CLA200S
Fiber Spacer



CLAS1659, CLA2822
Input Shaft 2" 10 Spline with Bushing



CLA12815
Bushing - Bell Housing



CLAFG100
Flywheel Gauge

CLUTCH INSTALLATION KITS

OUR "BASIC" CLUTCH INSTALLATION KIT (TORQUE-LIMITING CLUTCH BRAKE)



PART # CLAK2200 INCLUDES:

- (1) CLA105C137 Fork
- (1) CLA127760 2" Clutch Brake
- (4) CLA12815 Bushings

PART # CLAK2175 INCLUDES:

- (1) CLA105C137 Fork
- (1) CLA 127740 1.75" Clutch Brake
- (4) CLA12815 Bushings

OUR "BASIC" CLUTCH INSTALLATION KIT (HINGED CLUTCH BRAKE)



PART # CLAK2201 INCLUDES:

- (1) CLA105C137 Fork
- (1) CLA127200 2" Hinged Clutch Brake
- (4) CLA12815 Bushings

CLUTCH INSTALLATION KITS

FOR FR SERIES TRANSMISSION

CLAK3600 with Torque-Limiting Clutch Brake and Roller Bearing

CLAK3600B with 2" Hinged Clutch Brake (CLA127200) and Roller Bearing

FOR RT SERIES TRANSMISSION

CLAK2468 with Torque-Limiting Clutch Brake and Ball Bearing

CLAK2468B with 2" Hinged Clutch Brake (CLA127200) and Ball Bearing

CLAK3762 Severe-Duty with Torque-Limiting Clutch Brake and Roller Bearing

CLAK3762B Severe-Duty with 2" Hinged Clutch Brake (CLA127200) and Roller Bearing

COMPLETE CLUTCH INSTALLATION KITS INCLUDE:

- Clutch Housing Gasket
- Front Bearing Cover Gasket
- Inner Retaining Ring
- Outer Retaining Ring
- Front Bearing Cover
- Clutch Brake
- Shift Lever Housing Gasket
- Bearing with Snap Ring
- Pilot Bearing
- Cross Shaft Bushings
- Standard Release Yoke
- Input Shaft

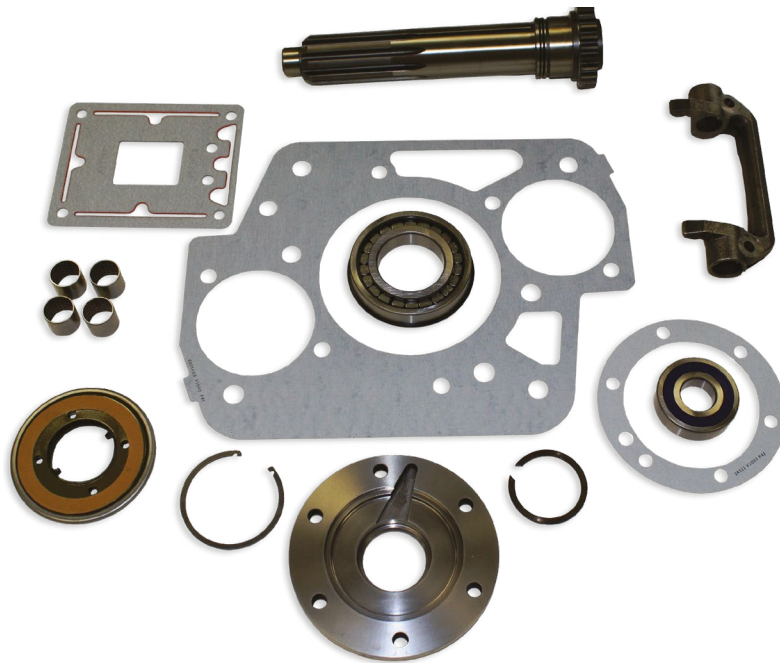

CLUTCH INSTALLATION TOOL KIT

PART # CLATK200



KIT CONTAINS:

Clutch Adjustment Gauge,
Disc Alignment Shaft, Clutch
Alignment Pins, Shaft Removal Tool,
and Flywheel Gauge



UTILIZING ROAD CHOICE TOOL KIT CLATK200



11. Bearing Height

Verify bearing height from cover assembly 1/2" - 5/8".

1. Pilot Bearing

Replace using Viton sealed bearing. Check on input shaft before installing in flywheel.

2. Alignment Pins

Install clutch alignment pins into top clutch mounting holes.

8. Mounting Bolts

Install 8 mounting bolts (7/16 x 14unc x 2-1/4 grade 5) with lock washers finger tight. Replace clutch alignment pins with bolts.

9. Add Bolts

Tighten mounting bolts in a criss-cross pattern starting with a bottom bolt. Torque to 40-50 ft-lb

10. T-Handle

Install T-handle in the end of alignment shaft and remove shaft only after shipping blocks have been removed.

3. Alignment Shaft

Install alignment shaft into pilot bearing.

4. Front Disc

Install front disc oriented correctly on alignment shaft. Verify flywheel bore.

5. Center Plate

Install center plate in flywheel housing with lugs between clutch alignment pins.

6. Rear Disc

Install rear disc oriented correctly on alignment shaft.

7. Clutch Cover

Install clutch cover assembly over alignment shaft, utilizing clutch alignment pins installing center plate in clutch cover

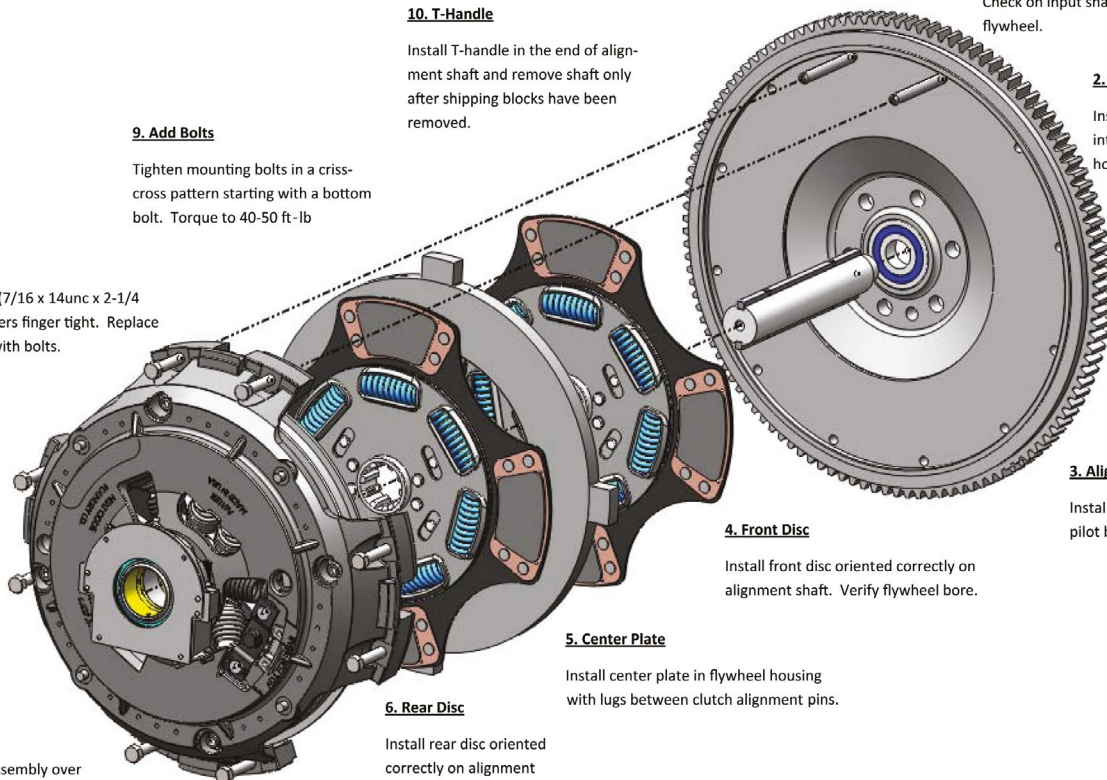

CLUTCH INSTALLATION GUIDELINES

READ CAREFULLY BEFORE INSTALLING CLUTCH

This clutch must be installed by a qualified installer. Improper installation, failure to replace or resurface the flywheel, or to replace the pilot bearing, clutch brake, or other worn drivetrain components may cause poor clutch release or early failure and void the manufacturer's warranty.

VERIFY CORRECT FLYWHEEL DIMENSIONS

Measure the flywheel bore to determine if you have the correct clutch for your application (See Fig. 1). This dimension will be 7", 8.5", or 10".

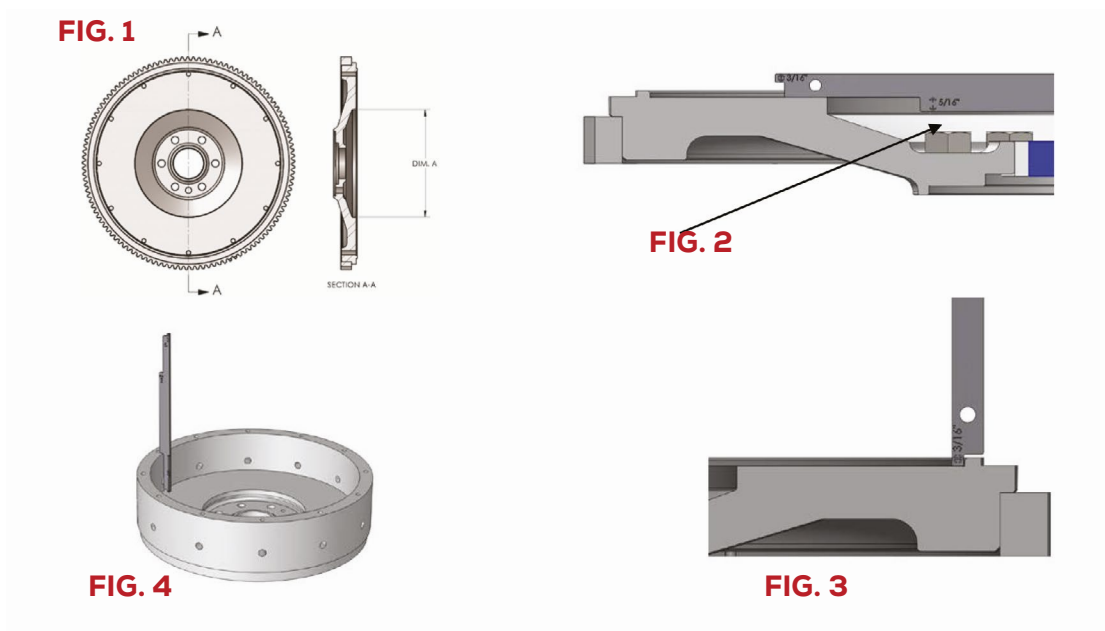

You must have a minimum of 5/16" distance from the friction surface (face) of your flywheel to the top of the bolt head that holds the flywheel to the crankshaft. If it is less than 5/16", you need a NEW flywheel! (See Fig. 2)

Flywheel clutch pilot cannot be greater than 3/16" deep. If it is greater than 3/16", the clutch will not bolt tight to flywheel. (See Fig. 3)

14" POT Flywheel dimension is 2.937". (See Fig. 4)

CLUTCH INSTALLATION GUIDELINES

- 1.** Resurface or replace flywheel. Surface must be smooth or premature clutch failure can occur.
REMEMBER: Machining the flywheel past the recommended .060" moves the pressure plate away from the transmission. In this event, install a fiber spacer (provided) on the input shaft between the clutch brake and the transmission. The release yoke in the bell housing may not align properly with the pressure plate release bearing housing. Linkage adjustment may be required during clutch setup. If resurfacing is required, while the flywheel is mounted to the crank shaft, verify correct flywheel dimensions by referencing page 29.
- 2.** 14" Pot Style Only: Drive pins in the flywheel must be replaced. Check and be sure drive pin heads are square with the flywheel friction surface. (If drive pins are not replaced, assume that they are not square. The constant pounding of the center plate may have changed the position of the drive pins in the flywheel. Play it safe – replace them all!)
- 3.** 14" Pot Style Only: After the drive pins are installed and properly aligned, position the center plate onto the drive pins and check the clearance with a feeler gauge. Clearance should be .006" to .010" and be measured from the same side of the drive pin at each location. The center plate should move up and down freely on the pins.
- 4.** Inspect and dial-indicate the mating surface of engine flywheel housing and clutch bell housing for alignment. Check flywheel run out. CAUTION: If misalignment is greater than the recommended limits, this will cause poor clutch release, rapid wear on transmission input shaft, and destruction of the clutch disc. Excessive flywheel run out may cause severe vibration in vehicle drive line (see Fig. 5).
- 5.** A new pilot bearing with a Viton® seal must be used. Before installing pilot bearing into flywheel, check freedom of movement on transmission input shaft.
- 6.** Verify disc fits in flywheel bore (Fig. 1). Slide disc the length of the input shaft, checking for twist and wear. Insert alignment shaft through bearing housing. Install rear disc (oriented correctly), center plate and front disc (oriented correctly) on alignment shaft. Move clutch housing toward flywheel, making sure cover fits into flywheel pilot.
- 7.** Install the bolts that fasten the clutch housing on the flywheel. Tighten the bolts to the specified torque and the sequence specified by the manufacturer of the vehicle or transmission (7/16" x 14 unc x 2 1/4" recommended 40-50 ft-lbs; 3/8" x 1 1/4" recommended 25-35 ft-lbs). Bolts should be Grade 5 or greater.
- 8.** Remove caging fork from under the release bearing. Remove alignment shaft. Verify bearing distance from cover is 1/2" to 5/8" (see Fig. 6). NOTE: Any time the clutch is removed from the flywheel, the caging fork needs to be reinstalled.
- 9.** Reconnect lube hose attachment (for Hydraulic Linkage Systems).
- 10.** Examine transmission input shaft and clutch release system components for wear, and replace if necessary (see Fig. 7).
- 11.** Install fiber spacer and replace clutch brake (fiber spacer not needed if over-sized clutch brake is used).

CLUTCH INSTALLATION GUIDELINES

FIG. 5: MEASURING ENGINE FLYWHEEL HOUSING AND FLYWHEEL

NOTE: Pilot bearing MUST be replaced. Make sure all gauge contact surfaces are clean and dry.

CHECK THE FOLLOWING USING A DIAL INDICATOR:

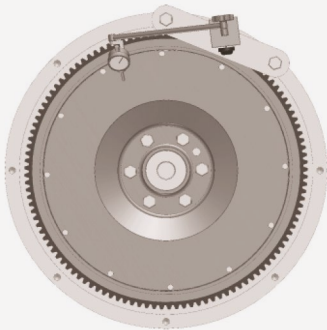

FLYWHEEL FACE RUNOUT

Secure dial indicator base to flywheel housing face. Put gauge finger in contact with flywheel face near the outer edge. Rotate flywheel one revolution. Maximum runout is .008" (.20 mm).

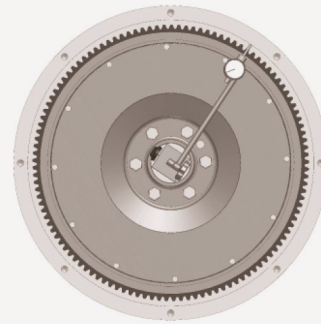

FLYWHEEL HOUSING I.D. RUNOUT

Secure dial indicator base to crankshaft. Put gauge finger against flywheel housing pilot I.D. Rotate flywheel one revolution. Maximum runout is .008" (.20 mm).

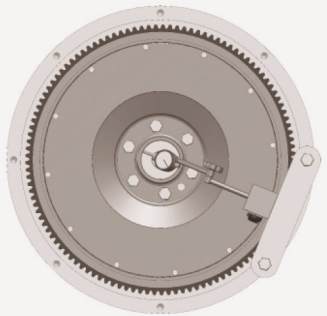

PILOT BEARING BORE RUNOUT

Secure dial indicator base to flywheel housing face. Position gauge finger so that it contacts pilot bearing bore. Rotate flywheel one revolution. Maximum runout is .005" (.13 mm).

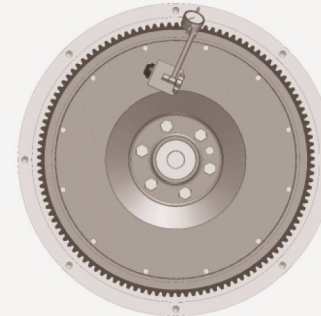

FLYWHEEL HOUSING FACE RUNOUT

Secure dial indicator base to flywheel near the outer edge. Put gauge finger in contact with face of flywheel housing. Rotate flywheel one revolution. Maximum runout is .008" (.20 mm).

CLUTCH INSTALLATION GUIDELINES

FIG. 6

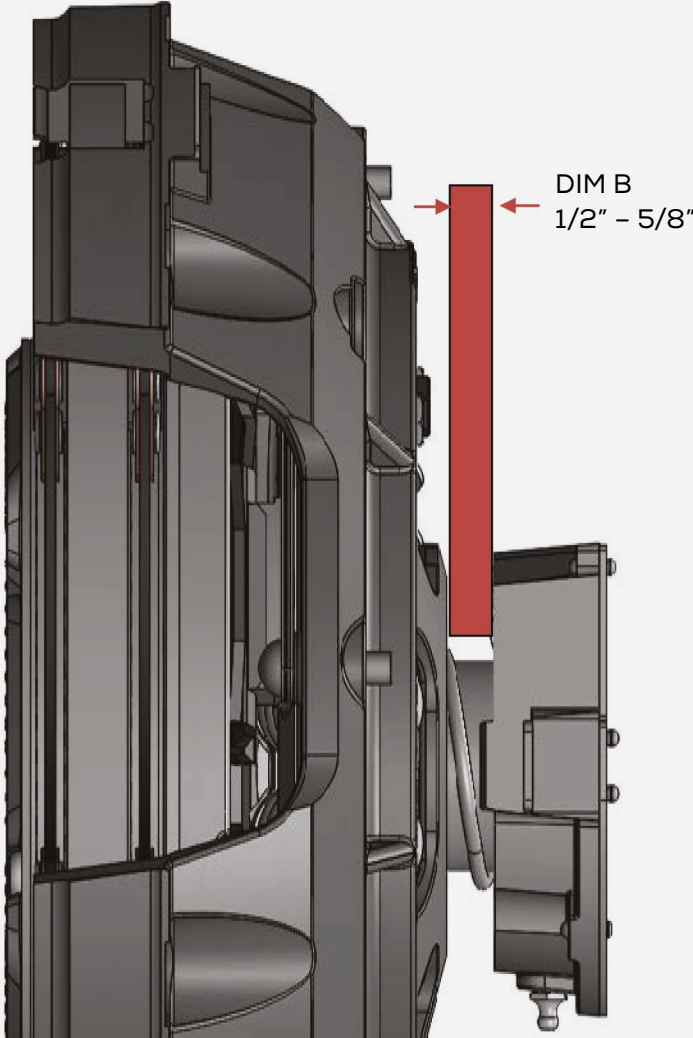

CLUTCH INSTALLATION GUIDELINES

FIG. 7

RELEASE YOKE

Worn fingers will cause sleeve bushing wear and adjustment problems.

CROSS SHAFT BUSHING

Worn cross shaft bushings allow sideways thrust on release bearing, causing wear on sleeve bushing and premature wear on release bearing.

CLUTCH BRAKE

A clutch brake is used on non-synchronized transmissions to slow or stop the input shaft when the clutch pedal is depressed. A clutch brake is designed to work at engine idle with the truck stopped. It needs to be replaced at every clutch installation.

TRANSMISSION BEARING RETAINER

Measured input shaft length should be 8.657". If longer than 8.71", transmission bearing retainer cap needs to be replaced. Worn or rough surface will lead to premature clutch brake wear and adjustment problems.

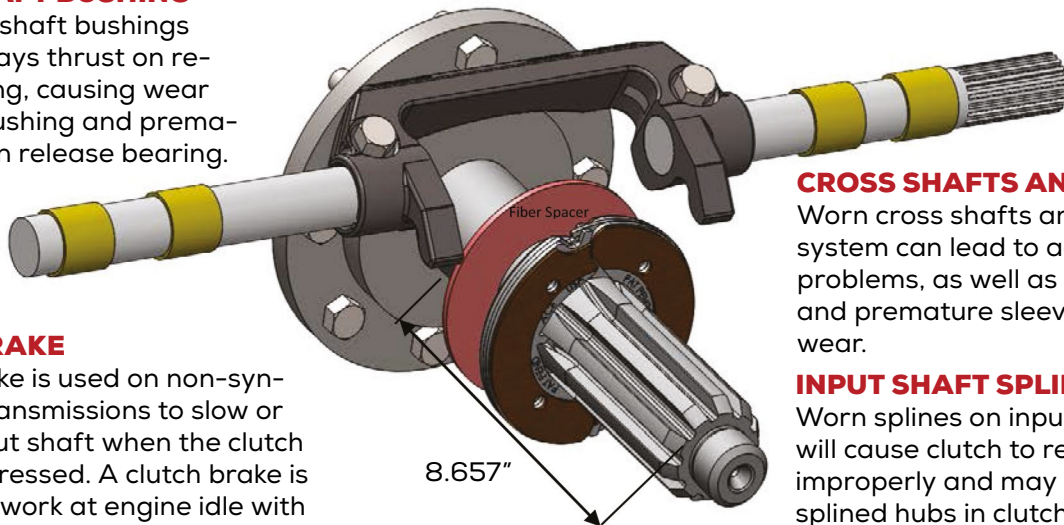

CROSS SHAFTS AND LINKAGE

Worn cross shafts and linkage system can lead to adjustment problems, as well as hard pedal and premature sleeve bushing wear.

INPUT SHAFT SPLINES

Worn splines on input shaft will cause clutch to release improperly and may cause splined hubs in clutch disc to break out.

INPUT SHAFT PILOT

Any wear in area will allow input shaft to wobble, creating vibration that leads to premature failure.

INPUT SHAFT

Roughness in bushing area will lead to sleeve bushing failure and can cause bushing to pull out of sleeve.

CLUTCH SETUP PROCEDURE

NOTE: Clutches are adjusted at the factory to original equipment specifications and should require very little internal adjustment to achieve proper release and engagement. The clutch must not be adjusted to accommodate thin or worn flywheels, worn linkage, yoke and/or cross shaft bushings, or to accommodate other drivetrain deficiencies. Adjustment for such purposes will either cause the clutch to not function properly or will cause early clutch failure and will be apparent on factory inspection of warranty claims, thereby voiding the manufacturer warranty.

STEP #1

After transmission installation, check the clearance between the yoke tips and wear pads on bearing housing for 1/8" clearance (see Fig. 8). This determines pedal free play (mechanical linkage only). Adjust the clutch linkage to increase or decrease the yoke-to-bearing clearance.

NEVER USE THE INTERNAL CLUTCH ADJUSTMENT FOR THIS PURPOSE.

STEP #2

Check for proper clutch brake and bearing gap of 1/2" to 9/16". If the gap is too small, verify DIM B (Fig. 6 or Fig. 8). If DIM B is correct and a fiber spacer or oversized clutch brake was installed, remove the fiber spacer and/or replace over-sized clutch brake with standard thickness clutch brake. NOTE: If the gap is larger than 9/16" and DIM B is correct, then one of the following conditions exists: either fiber spacer/over-sized clutch brake was not installed or you need to re-measure input shaft length as seen in Fig. 7. **DO NOT ADJUST THE CLUTCH!**

THIS DIMENSION IS CRITICAL. DO NOT VARY – EITHER OVER OR UNDER THESE DIMENSIONS – UNDER ANY CIRCUMSTANCES.

REMINDER: The bearing must move a minimum of 1/2" or clutch will not release. Eliminate lost motion before checking for 1/2" movement. Lost motion is generally caused by loose or worn linkage, or worn yoke or cross shaft bushings.

STEP #3

Verify the clutch brake squeeze by inserting .010" feeler gauge between bearing and clutch brake, then depressing the pedal to end of stroke. The feeler gauge must be tightly clamped between the bearing and the clutch brake. This verifies the contact of the bearing to the clutch brake. The clutch brake will be squeezed if the total pedal stroke slightly exceeds the movement required to move the yoke/fork 5/8" to 11/16" (the combined total of the 1/8" clearance between yoke tips and wear pads and the 1/2" – 9/16" brake squeeze gap). To optimize brake, squeeze slowly let up on the pedal and check the pedal position at the moment the .010" feeler gauge can be removed. If the pedal is less than 1/2" or more than 1" from the floor when gauge can be removed, re-adjust the linkage.

IN THE EVENT THE BRAKE IS NOT BEING SQUEEZED, DO NOT CHANGE THE 1/2" – 9/16" GAP FOR THE CLUTCH BRAKE OR THE 1/8" CLEARANCE FOR THE BEARING HOUSING – CONSULT THE VEHICLE MANUFACTURER SERVICE MANUAL.

In analyzing the reasons for the brake not being squeezed, other things to check for are:

- A.** Worn linkage components or yoke and cross shaft bushings. If necessary, replace those components.
- B.** Improper linkage assembly. Verify that linkage is assembled in the correct hole locations.
- C.** Pedal stroke. To adjust, raise the upper and/or lower the lower pedal stops.
- D.** If the clutch is hydraulically assisted, make sure the slave and master cylinders are functioning properly.

NOTE: MAXIMUM BRAKE SQUEEZE (IN CAB OF TRUCK) SHOULD NOT EXCEED 1" FROM THE END OF PEDAL STROKE. IF IT DOES, IT CAN BE ADJUSTED BY:

- A.** Changing pedal stops in cab to reduce total pedal stroke.
- B.** Increasing 1/8" yoke-to-bearing setting to lower squeeze. (This will increase free-pedal travel.)

CLUTCH SETUP PROCEDURE

STEP #4

Installer should carefully verify that there is 1/2" to 5/8" gap between clutch cover and release bearing, 1/8" of free travel between yoke and wear pads (mechanical linkage only), and 1/2" to 9/16" gap between release bearing and clutch brake.

FIG. 8

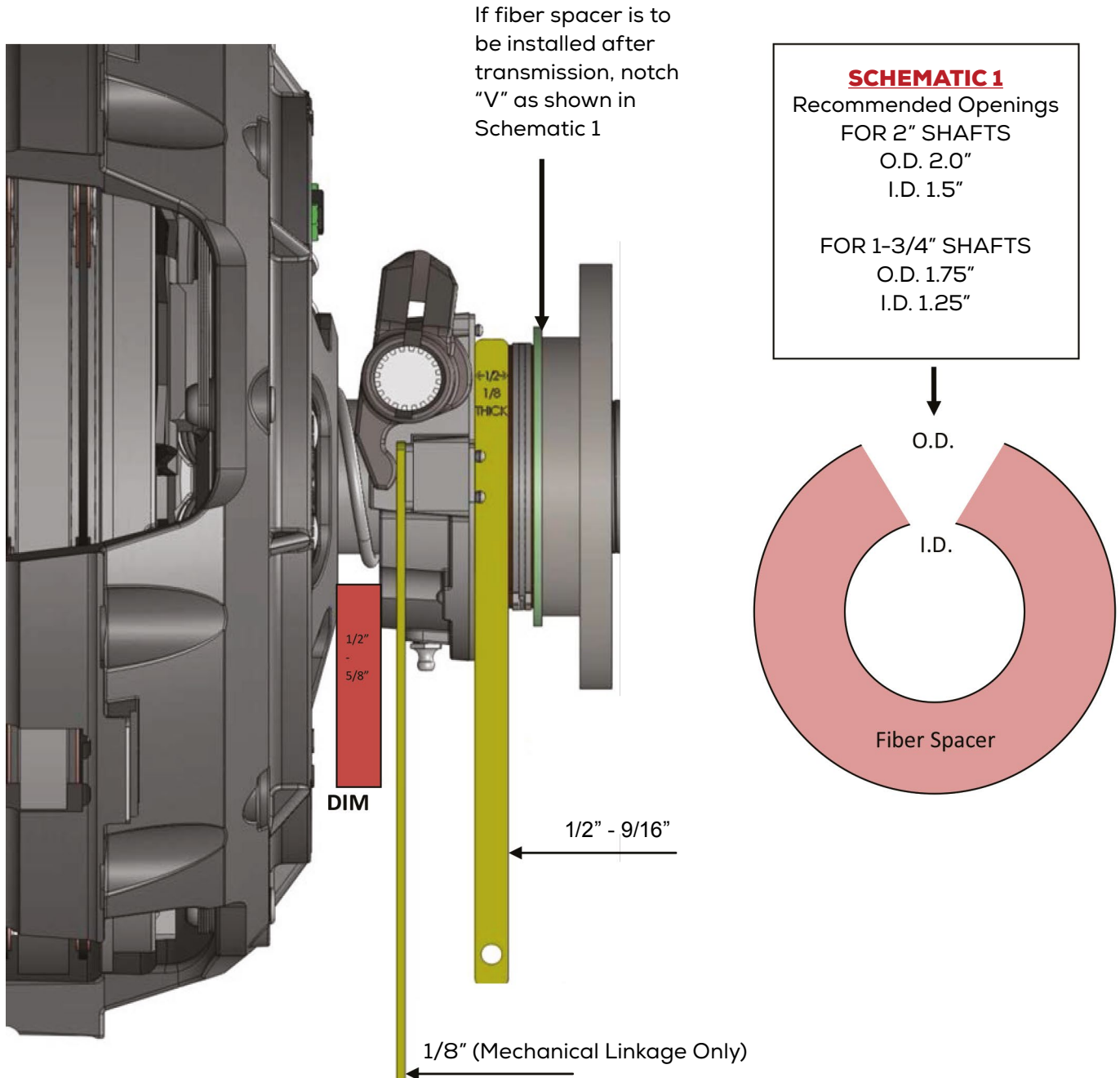

INSTALLATION TROUBLESHOOTING AND DIAGNOSTICS

BEARING TO COVER POSITION IS TOO LARGE (GREATER THAN 5/8")

- Disc in backward
- 5/16" flywheel dimension is too small and disc is hitting crank bolts (See Fig. 2)
- Flywheel bore is smaller than clutch disc (See Fig. 1)
- 14" POT Flywheel 2.937" dimension is not correct (See Fig. 4)

BEARING TO COVER POSITION IS TOO SMALL (LESS THAN 1/2")

- Flywheel not resurfaced
- Flywheel clutch pilot is more than 3/16" (See Fig. 3)
- Forgot to install a disc
- 14" POT Flywheel 2.937" dimension is not correct (See Fig. 4)

BEARING TO CLUTCH BRAKE GAP IS GREATER THAN 9/16"

- Verify bearing position is in spec between 1/2" to 5/8" (See Fig. 8)
- Input shaft measurement is too long/excessive wear on transmission input bearing retainer (See Fig. 7)
- Did not use over-sized clutch brake or fiber spacer

BEARING TO CLUTCH BRAKE GAP IS LESS THAN 1/2"

- Verify bearing position is in spec between 1/2" to 5/8" (See Fig. 8)
- Used over-sized clutch brake instead of standard clutch brake
- Have fiber spacer and don't need it

FREE TRAVEL IS OUT OF SPEC (MECHANICAL LINKAGE SYSTEMS ONLY)

- Verify bearing position is in spec between 1/2" to 5/8" (See Fig. 8)
- Verify bearing to brake gap is in spec between 1/2" to 9/16" (See Fig. 8)
- Release system linkage components are worn; need to be adjusted or replaced (See Fig. 8)

SELF-ADJUST CLUTCH INSTALLATION GUIDELINES

READ CAREFULLY BEFORE INSTALLING CLUTCH

This clutch must be installed by a qualified installer. Improper installation, failure to replace or resurface the flywheel, or to replace the pilot bearing, clutch brake or other worn drivetrain components may cause poor clutch release or early failure and void the manufacturer's warranty.

VERIFY CORRECT FLYWHEEL DIMENSIONS

Flywheel bore (DIM A) must be a minimum of 10". (See Fig. 1)

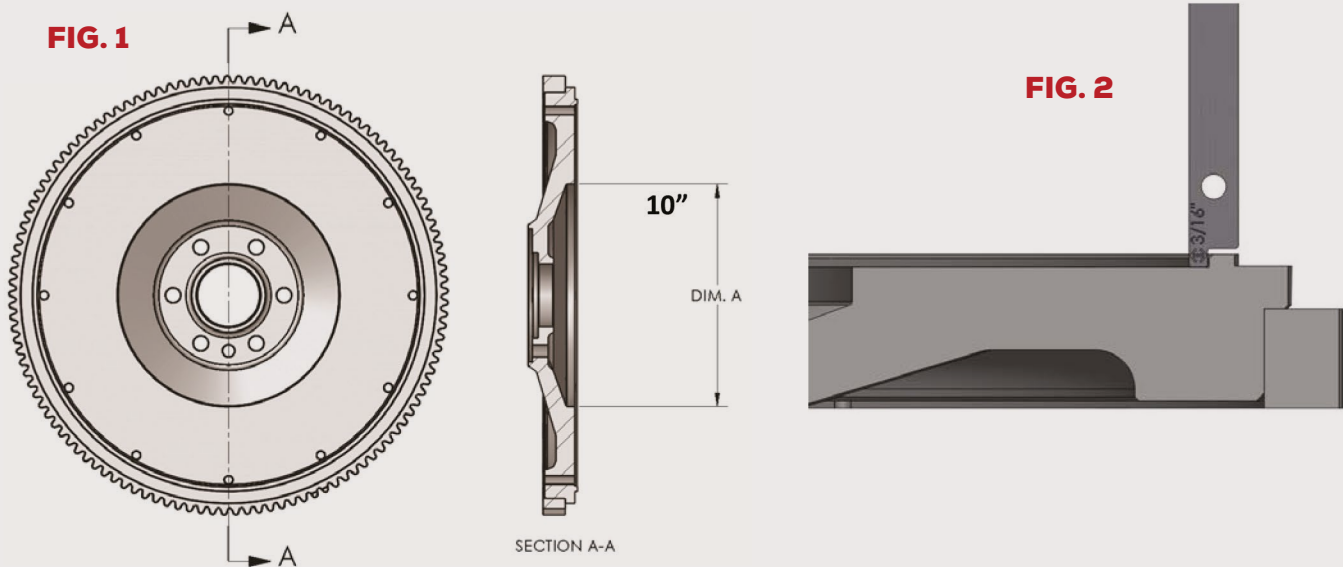
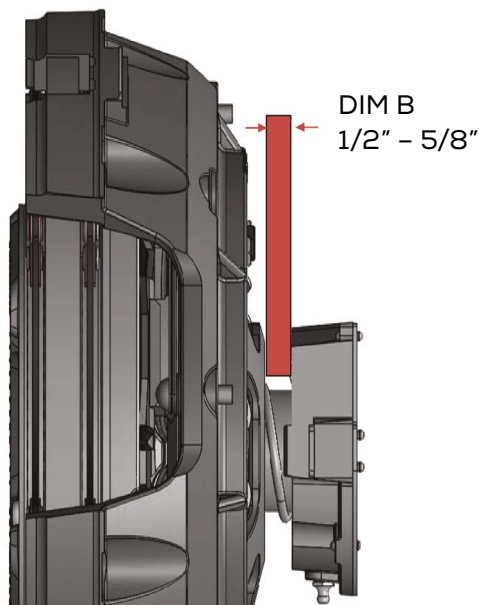

FIG. 3

You must have a minimum of 5/16" distance from the friction surface (face) of your flywheel to the top of the bolt head that holds the flywheel to the crankshaft. If it is less than 5/16", you need a NEW flywheel! (See Fig. 3) Flywheel clutch pilot cannot be greater than 3/16" deep. If it is greater than 3/16" the clutch will not bolt tight to flywheel. (See Fig. 2)

SELF-ADJUST CLUTCH INSTALLATION GUIDELINES

- 1.** Resurface or replace flywheel. Surface must be smooth or premature clutch failure can occur. REMEMBER: Machining the flywheel past the recommended .060" moves the pressure plate away from the transmission. In this event, install a fiber spacer (provided) on the input shaft between the clutch brake and the transmission. The release yoke in the bell housing may not align properly with the pressure plate release bearing housing. Linkage adjustment may be required during clutch set up. If resurfacing is required, while the flywheel is mounted to the crank shaft, verify correct flywheel dimensions as seen in Fig. 2 and Fig. 3.
- 2.** Inspect and dial-indicate the mating surface of engine flywheel housing and clutch bell housing for alignment. Check flywheel run out. CAUTION: If misalignment is greater than the recommended limits, this will cause poor clutch release, rapid wear on transmission input shaft, and destruction of the clutch disc. Excessive flywheel run out may cause severe vibration in vehicle drive line (See Fig. 5 on following page).
- 3.** A new pilot bearing with a Viton® seal must be used. Before installing pilot bearing into flywheel, check freedom of movement on transmission input shaft.
- 4.** Verify disc fits in flywheel bore (Fig. 1). Slide disc the length of the input shaft, checking for twist and wear. Insert alignment shaft through bearing housing. Install rear disc (oriented correctly), center plate and front disc (oriented correctly) on alignment shaft. Move clutch housing toward flywheel making sure cover fits into flywheel pilot.
- 5.** Install the bolts (7/16" x 14unc x 2 1/4") that fasten the clutch housing on the flywheel. Tighten the bolts to the specified torque and the sequence specified by the manufacturer of the vehicle or transmission (Recommended 40-50 ft-lbs). Bolts should be Grade 5 or greater.
- 6.** Remove caging fork from under the release bearing. Remove alignment shaft. Verify bearing distance from cover is 1/2" to 5/8" (See Fig. 4). NOTE: Any time the clutch is removed from the flywheel, the caging fork needs to be reinstalled. Failure to do so will cause adjusting arm to fall out of retainer stud. See Fig. 9 in Reset Procedure on page 44.



SELF-ADJUST CLUTCH INSTALLATION GUIDELINES

FIG.5: MEASURING ENGINE FLYWHEEL HOUSING AND FLYWHEEL

NOTE: Pilot bearing **MUST** be replaced. Make sure all gauge contact surfaces are clean and dry.

CHECK THE FOLLOWING USING A DIAL INDICATOR:

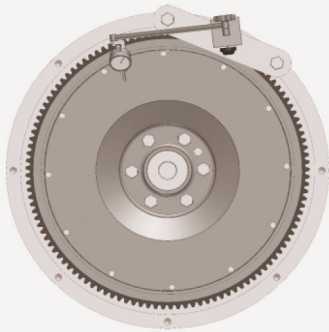

FLYWHEEL FACE RUNOUT

Secure dial indicator base to flywheel housing face. Put gauge finger in contact with flywheel face near the outer edge. Rotate flywheel one revolution. Maximum runout is .008" (.20 mm).

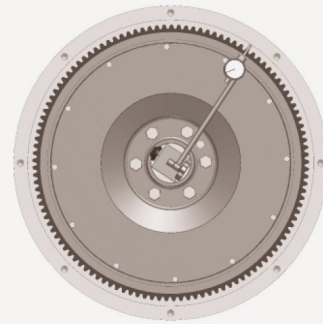

FLYWHEEL HOUSING I.D. RUNOUT

Secure dial indicator base to crankshaft. Put gauge finger against flywheel housing pilot I.D. Rotate flywheel one revolution. Maximum runout is .008" (.20 mm).

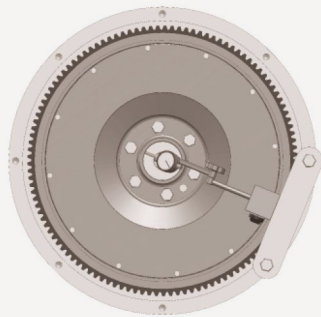

PILOT BEARING BORE RUNOUT

Secure dial indicator base to flywheel housing face. Position gauge finger so that it contacts pilot bearing bore. Rotate flywheel one revolution. Maximum runout is .005" (.13 mm).

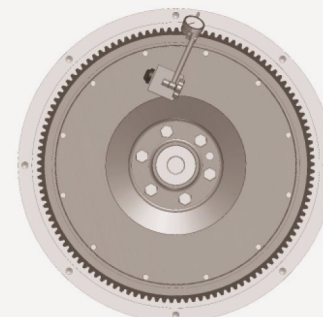

FLYWHEEL HOUSING FACE RUNOUT

Secure dial indicator base to flywheel near the outer edge. Put gauge finger in contact with face of flywheel housing. Rotate flywheel one revolution. Maximum runout is .008" (.20 mm).

SELF-ADJUST CLUTCH INSTALLATION GUIDELINES

CONTINUED FROM PAGE 38

7. Reconnect lube hose attachment (for Hydraulic Linkage Systems).
8. Examine transmission input shaft and clutch release system components for wear and replace if necessary (See Fig. 6).
9. Install fiber spacer and replace clutch brake (fiber spacer not needed if over-sized clutch brake is used).
10. Be sure to properly lube the following components with NLGI grade 2 or 3 lithium complex grease: release bearing, yoke fingers, cross shaft bushings, and linkage pivot points. NOTE: Applying enough grease to the release bearing until visible will extend the life of sleeve bushings and input shaft.

FIG. 6

TRANSMISSION BEARING RETAINER

Measured input shaft length should be 8.657". If longer than 8.71", transmission bearing retainer cap needs to be replaced. Worn or rough surface will lead to premature clutch brake wear and adjustment problems.

RELEASE YOKE

Worn fingers will cause sleeve bushing wear and adjustment problems.

TRANSMISSION BEARING

Wear will allow input shaft to wobble, creating vibration that leads to premature failure.

CROSS SHAFT BUSHING

Worn cross shaft bushings allow sideways thrust on release bearing, causing wear on sleeve bushing and premature wear on release bearing.

CROSS SHAFTS AND LINKAGE

Worn cross shafts and linkage system can lead to adjustment problems, as well as hard pedal and premature sleeve bushing wear.

CLUTCH BRAKE

A clutch brake is used on non-synchronized transmissions to slow or stop the input shaft when the clutch pedal is depressed. A clutch brake is designed to work at engine idle with the truck stopped. It needs to be replaced at every clutch installation.

INPUT SHAFT

Roughness in bushing area will lead to sleeve bushing failure and can cause bushing to pull out of sleeve.

INPUT SHAFT SPLINES

Worn splines on input shaft will cause clutch to release improperly and may cause splined hubs in clutch disc to break out.

INPUT SHAFT PILOT

Any wear in area will allow input shaft to wobble, creating vibration that leads to premature failure.

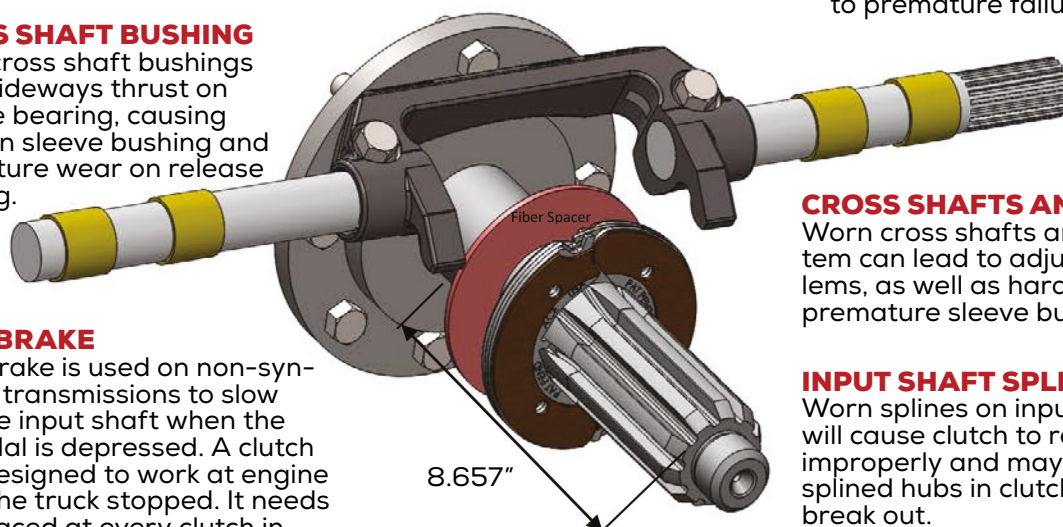

11. Using extreme caution, guide transmission through clutch cover and disc assemblies, then into pilot bearing rotating bell housing shaft so that release yoke fingers are clear of the pads on the release bearing assembly. (WARNING: Transmission must not hang or be forced into the clutch. This can warp the clutch disc and prevent the clutch from releasing.) NOTE: Do not add lube to input shaft splines!
12. Start bell housing bolts and tighten progressively to the torque recommended by the vehicle manufacturer.
13. Install clutch linkage. See "Self-Adjust Clutch Setup Procedure" on the following page.

SELF-ADJUST CLUTCH SETUP PROCEDURE

NOTE: Clutches are adjusted at the factory to original equipment specifications and should require very little internal adjustment to achieve proper release and engagement. The clutch must not be adjusted to accommodate thin or worn flywheels, or worn linkage, yoke and/or cross shaft bushings, or to accommodate other drivetrain deficiencies. Adjustment for such purposes will either cause the clutch to not function properly or will cause early clutch failure and will be apparent on factory inspection of warranty claims, thereby voiding the manufacturer warranty.

STEP #1

After transmission installation, check the clearance between the yoke tips and wear pads on bearing housing for 1/8" clearance (see Fig. 7). This determines pedal free play (mechanical linkage only). Adjust the clutch linkage to increase or decrease the yoke-to-bearing clearance.

NEVER USE THE INTERNAL CLUTCH ADJUSTMENT FOR THIS PURPOSE.

STEP #2

Check for proper clutch brake and bearing gap of 1/2" to 9/16". If the gap is too small, verify DIM B (Fig. 4 or Fig. 7). If DIM B is correct and a fiber spacer or oversized clutch brake was installed, remove the fiber spacer and/or replace oversized clutch brake with standard thickness clutch brake.

NOTE: If the gap is larger than 9/16" and DIM B is correct, then one of the following conditions exists: either fiber spacer/oversized clutch brake was not installed or you need to re-measure input shaft length as seen in Fig. 6. **DO NOT ADJUST THE CLUTCH! THIS DIMENSION IS CRITICAL. DO NOT VARY – EITHER OVER OR UNDER THESE DIMENSIONS – UNDER ANY CIRCUMSTANCES.**

REMINDER: The bearing must move a minimum of 1/2" or clutch will not release. Eliminate lost motion before checking for 1/2" movement. Lost motion is generally caused by loose or worn linkage, or worn yoke or cross shaft bushings.

STEP #3

Verify the clutch brake squeeze by inserting .010" feeler gauge between bearing and clutch brake, then depressing the pedal to end of stroke. The feeler gauge must be tightly clamped between the bearing and the clutch brake. This verifies the contact of the bearing to the clutch brake.

The clutch brake will be squeezed if the total pedal stroke slightly exceeds the movement required to move the yoke/fork 5/8" to 11/16" (the combined total of the 1/8" clearance between yoke tips and wear pads and the 1/2" to 9/16" brake squeeze gap). To optimize brake squeeze, slowly let up on the pedal and check the pedal position at the moment the .010" feeler gauge can be removed. If the pedal is less than 1/2" or more than 1" from the floor when gauge can be removed, readjust the linkage.

IN THE EVENT THE BRAKE IS NOT BEING SQUEEZED, DO NOT CHANGE THE 1/2" TO 9/16" GAP FOR THE CLUTCH BRAKE, OR THE 1/8" CLEARANCE FOR THE BEARING HOUSING—CONSULT THE VEHICLE MANUFACTURER SERVICE MANUAL.

In analyzing the reasons for the brake not being squeezed, other things to check for are:

- A.** Worn linkage components or yoke and cross shaft bushings. If necessary, replace those components.
- B.** Improper linkage assembly. Verify that linkage is assembled in the correct hole locations.
- C.** Pedal stroke. To adjust, raise the upper and/or lower the lower pedal stops.
- D.** If the clutch is hydraulically assisted, make sure the slave and master cylinders are functioning properly.

NOTE: MAXIMUM BRAKE SQUEEZE (IN CAB OF TRUCK) SHOULD NOT EXCEED 1" FROM THE END OF PEDAL STROKE. IF IT DOES, IT CAN BE ADJUSTED BY:

- A.** Changing pedal stops in cab to reduce total pedal stroke.
- B.** Increasing 1/8" yoke-to-bearing setting to lower squeeze. (This will increase free-pedal travel.)

SELF-ADJUST CLUTCH SETUP PROCEDURE

STEP #4

Installer should carefully verify that there is 1/2" to 5/8" gap between clutch cover and release bearing, 1/8" of free travel between yoke and wear pads (mechanical linkage only), and 1/2" to 9/16" gap between release bearing and clutch brake.

FIG. 7

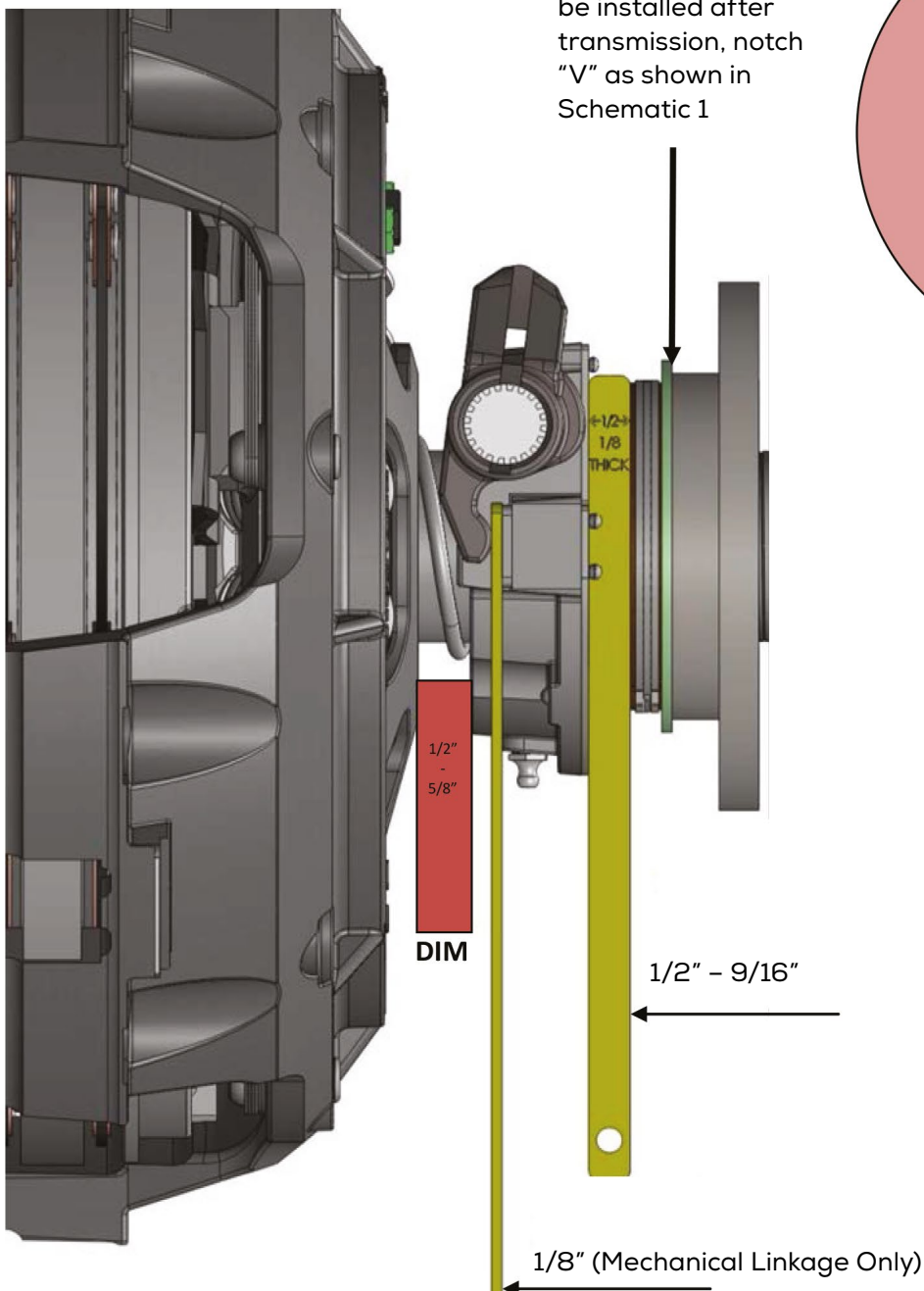

If fiber spacer is to be installed after transmission, notch "V" as shown in Schematic 1

SCHEMATIC 1

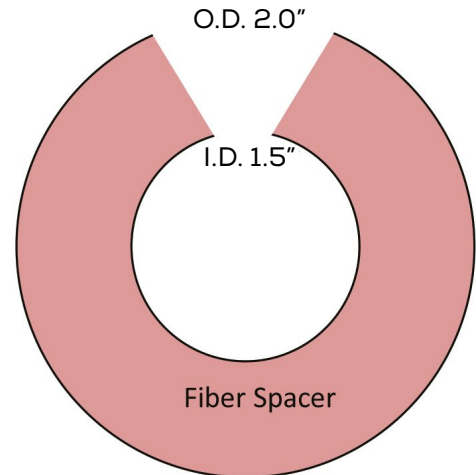

SELF-ADJUST CLUTCH TROUBLESHOOTING AND DIAGNOSTICS

BEARING POSITION TOO LARGE (GREATER THAN 5/8")

- Disc in backward
- 5/16" flywheel dimension is too small and disc is hitting crank bolts (See Fig. 3)
- Flywheel bore is smaller than 10" (See Fig. 1)

BEARING POSITION TOO SMALL (LESS THAN 1/2")

- Flywheel not resurfaced
- Flywheel clutch pilot is more than 3/16" (See Fig. 2)
- Forgot to install a disc
- NOTE: If any of the previous situations occur, verify the adjuster arm is still inserted in stud (See Fig. 9)

BEARING TO CLUTCH BRAKE GAP IS GREATER THAN 9/16"

- Verify bearing position is in spec between 1/2" to 5/8" (See Fig. 7)
- Input shaft measurement is too long/excessive wear on transmission input bearing retainer (See Fig. 6)
- Did not use over-sized clutch brake or fiber spacer
- Self-adjust mechanism not working – See Reset Procedure on the following page

BEARING TO CLUTCH BRAKE GAP IS LESS THAN 1/2"

- Verify bearing position is in spec between 1/2" to 5/8" (See Fig. 7)
- Used oversized clutch brake instead of standard clutch brake
- Have fiber spacer and don't need it

FREE TRAVEL IS OUT OF SPEC (MECHANICAL LINKAGE SYSTEMS ONLY)

- Verify bearing position is in spec between 1/2" to 5/8" (See Fig. 7)
- Verify bearing-to-brake gap is in spec between 1/2" to 9/16" (See Fig. 7)

SELF-ADJUST RESET PROCEDURE

If for any reason the clutch needs to be reset or manually adjusted, follow the instructions below.

1. Remove self-adjusting mechanism (Fig. 8)
2. Disengage clutch
3. Install manual-adjust mechanism (Fig. 8)
4. Manually adjust clutch to meet specs in setup procedure (Fig. 7)
5. Reinstall self-adjusting mechanism, and ensure adjusting arm is properly seated in the retainer stud (Fig. 9)
6. When reinstalling self-adjusting mechanism, it may be necessary to manually ratchet the self-adjust mechanism so that the worm gear is seated properly in the adjusting ring teeth

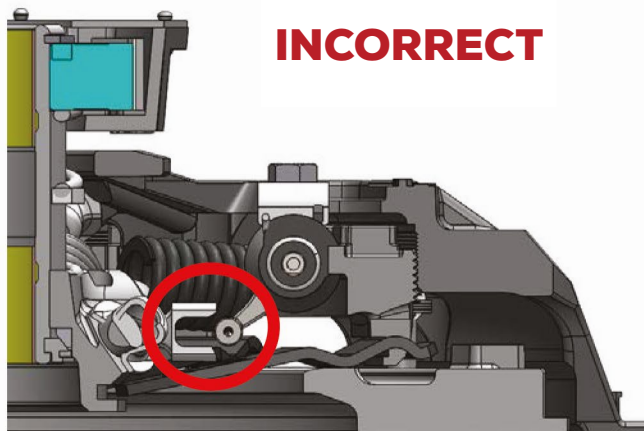
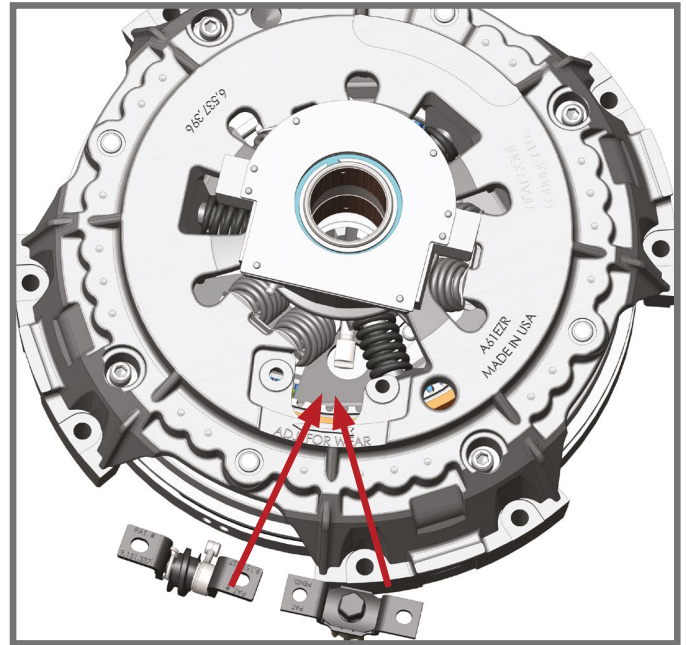
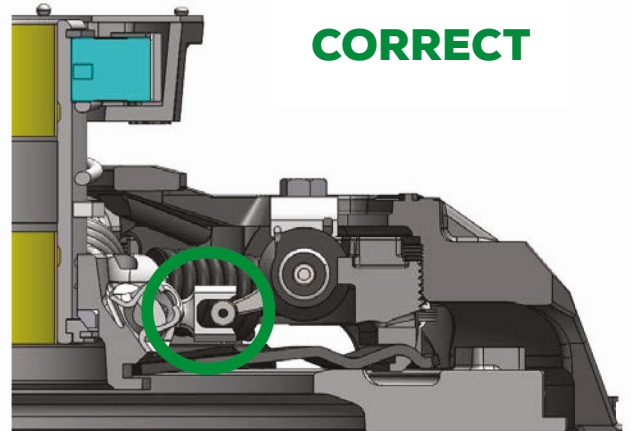

FIG. 9



MAINTENANCE TIPS

IT IS IMPORTANT TO NOTE THAT THESE ARE GENERAL GUIDELINES ONLY AND THAT THE INSTALLER SHOULD ALWAYS REFER TO THE VEHICLE MAINTENANCE MANUAL FOR SPECIFIC DETAILS.

RECOMMENDED LUBE:

Line Haul – 50,000 miles or 3 months; Vocational – 250 hours or 1 month.

- 1.** Only high-temperature grease should be used for clutch bearing housing and linkage lubrication. Do not use chassis lubricant for clutch lubrication. Refer to the vehicle maintenance manual for lubricant specifications.
- 2.** Lubricate the clutch release bearing each time the chassis is lubricated.
- 3.** When lubricating the clutch, apply lubricant to each fitting on the clutch housing.
- 4.** Every point in the clutch linkage must be lubricated, in addition to the clutch housing.
- 5.** Exercise caution in lubricating the bearing, as any excess lubricant will find its way onto the clutch facing.
- 6.** Manual adjust clutches must be adjusted once half the pedal free-travel has been lost. Failure to do so will result in slippage, and adjustment afterward may not be effective.
- 7.** If the clutch is hydraulically assisted, make sure the slave and master cylinders are functioning properly.

ENGINE HP AND TORQUE RATINGS

The data listed here has been compiled from vehicle manufacturers and other reliable sources of information and is correct to the best of our knowledge. However, Road Choice cannot assume any responsibility for the accuracy of or possible errors in this information or in any other current or future informative bulletins of this nature.

NOTE: RATE VARIABLE HORSEPOWER ENGINES TO HIGHEST HORSEPOWER/TORQUE.

ENGINE	HP	@ RPM	TORQUE	@ RPM
3116	195	2200	521	1560
6CTA-250	250	2200	720	1300
CAT 3066	260	1900	860	1350
CAT 3116	185	2600	520	1560
CAT 3116	215	2200	605	1560
CAT 3116	230	2200	660	1560
CAT 3116	250	2200	660	1560
CAT 3116	275	2200	750	1560
CAT 3116 (GM '91 UP)	215	2600	605	1560
CAT 3116 (GM MD)	275	2450	735	1560
CAT 3116 (GM-MD)	250	2600	650	1560
CAT 3116 (GM-MD)	300	2600	732	1560
CAT 3116 (HEUI)	170	2200	420	1560
CAT 3116 (MD)	170	2600	420	1560
CAT 3116 (MD)	200	2600	520	1560
CAT 3116G	185	2600	495	1560
CAT 3126	175	2400	420	1440
CAT 3126	190	2200	520	1440
CAT 3126	210	2200	605	1440
CAT 3126	230	2200	660	1440
CAT 3126	250	2200	800	1440
CAT 3126	275	2200	860	1440
CAT 3126	300	2200	860	1440
CAT 3176 ATMC	250	2100	975	1300
CAT 3176 ATMC	275	2100	1050	1200
CAT 3176 ATMC	300	2100	1150	1300
CAT 3176 ELEC	275	1800	1050	1100
CAT 3176 ELEC	275	1800	975	1100
CAT 3176 ELEC	300	1800	1050	1100
CAT 3176ATMC	325	2100	1225	1300
CAT 3176ATTMC	230	1800	975	1100
CAT 3176B	275	1800	1050	1100
CAT 3176B	300	1800	1050	1100
CAT 3176B	325	1800	1250	1200
CAT 3176B	350	1800	1350	1200
CAT 3208T (MD)	250	2600	640	1400
CAT 3208T(MD)	200	2000	620	1400
CAT 3306	245	2100	860	1350
CAT 3306	250	1800	860	1350
CAT 3306	270	2200	775	1400
CAT 3306C	300	1900	1150	1200

ENGINE HP AND TORQUE RATINGS

NOTE: RATE VARIABLE HORSEPOWER ENGINES TO HIGHEST HORSEPOWER/TORQUE.

ENGINE	HP	@ RPM	TORQUE	@ RPM
CAT 3406	250	1600	1000	1200
CAT 3406	280	2100	1015	1200
CAT 3406	290	1800	1000	1200
CAT 3406	300	2100	1054	1200
CAT 3406	310	1800	1090	1200
CAT 3406	310	1800	1140	1100
CAT 3406	325	2100	1050	1200
CAT 3406	330	1600	1320	1200
CAT 3406	380	2100	1285	1200
CAT 3406	400	1900	1450	1250
CAT 3406	455	2100	1650	1200
CAT 3406	475	2100	1650	1750
CAT 3406	500	2100	1850	1200
CAT 3406	550	2100	1850	1200
CAT 3406 510	510	1600	1850	1200
CAT 3406B	350	2100	1320	1200
CAT 3406B	400	2100	1375	1260
CAT 3406B	425	2100	1450	1200
CAT 3406BEC	400	2100	1265	1300
CAT 3406BEC	400	1800	1375	1260
CAT 3406C	350	1800	1350	1200
CAT 3406C	425	1900	1650	1200
CAT 3406E	310	1800	1250	1200
CAT 3406E	330	1800	1350	1200
CAT 3406E	375	1800	1450	1200
CAT 3406E	410	1800	1450	1200
CAT 3406E	435	2100	1650	1200
CAT 3406E	475	2100	1750	1200
CAT 3406E	550	1800	1850	1200
CAT 3406E	600	2100	2050	1200
CAT 3406E MULTI TQ	310	1800	1150/1350	1200
CAT 3406E MULTI TQ	355	1800	1350/1450	1200
CAT 3406E MULTI TQ	375	1800	1450/1550	1200
CAT 3406E MULTI TQ	375/435	1800	1450/1550	1200
CAT 3406E(94)	355	1800	1450	1200
CAT 3406E(94)	375	1800	1550	1200
CAT 3406E(94)	410	1800	1550	1200
CAT 3406E(94)	435	1800	1650	1200
CAT 3406E(94)	475	1800	1750	1200
CAT 3406E(94)	500	1800	1850	1200
CAT 3408	420	1900	1460	1200
CAT 3408	450	2100	1460	1200
CAT 63306 CNG/LNG	235	2100	800	1200
CAT 63306 LPG (HD5)	250	2100	820	1200
CAT C-10	280	1800	1050	1100

ENGINE HP AND TORQUE RATINGS

NOTE: RATE VARIABLE HORSEPOWER ENGINES TO HIGHEST HORSEPOWER/TORQUE.

ENGINE	HP	@ RPM	TORQUE	@ RPM
CAT C-10	305	2100	1150	1100
CAT C-10	325	2100	1250	1200
CAT C-10	335	1800	1350	1200
CAT C-10	350	1800	1350	1200
CAT C-10	370	1800	1350	1200
CAT C-10 MULTI	335/370	1800	1250/1350	1200
CAT C-11	305	2100	1050	1200
CAT C-11	335	2100	1250	2100
CAT C-11	350	2100	1450	1200
CAT C-11	370	2100	1450	1200
CAT C-12	355	1800	1350	1200
CAT C-12	360	2100	1350	1200
CAT C-12	380	1800	1450	1200
CAT C-12	390	2100	1450	1200
CAT C-12	410	2100	1550	1200
CAT C-12 MULTI TQ	355/410	1800	1350/1550	1200
CAT C-12 MULTI TQ	380/410	1800	1450/1550	1260
CAT C-12 RCVBUS	425	2100	1450	1200
CAT C-13	305	2100	1150	1200
CAT C-13	335	2100	1250	1260
CAT C-13	350	2100	1550	1200
CAT C-13	370	2100	1450	1200
CAT C-13	380	2100	1450	1200
CAT C-13	410	2100	1550	1200
CAT C-13	430	2100	1650	1200
CAT C-13	470	2100	1650	1200
CAT C-13 MULTI TORQUE	410	2100	1450/1650	1200
CAT C-13 MULTI TORQUE	430	2100	1550/1750	1200
CAT C-13 MULTI TORQUE	470	2100	1550/1750	1200
CAT C-15	435	2100	1650	
CAT C-15	475	2100	1850	
CAT C-15	500	2100	1850	
CAT C-15	550	2100	1850	
CAT C-15	600	2100	2050	
CAT C-15	625	2100	2050	
CAT C-15 MULTI TORQUE	435	2100	1550/1750	
CAT C-15 MULTI TORQUE	475	2100	1650/1750	
CUM 1-10	260	1800	975	1200
CUM 1-10	270	2100	858	1400
CUM 1-10 310	310	1800	1150	1200
CUM 1-10 330E	330	1800	1250	1200
CUM 444	444	2100	1400	1500
CUM 4BT3.9	105	2500	260	1700
CUM 4BT3.9	105	2500	260	1700
CUM 4BTA3.9	120	2500	304	1700

ENGINE HP AND TORQUE RATINGS

NOTE: RATE VARIABLE HORSEPOWER ENGINES TO HIGHEST HORSEPOWER/TORQUE.

ENGINE	HP	@ RPM	TORQUE	@ RPM
CUM 6BT55.9	160	2500	400	1700
CUM 6BTA5.9	190	2500	475	1600
CUM 6BTA5.9	210	2500	520	1600
CUM 6BTA5.9	230	2500	605	1600
CUM 6CT8.3	210	2200	605	1500
CUM 6CTA8.3	240	2200	645	1500
CUM 6CTA8.3	250	2200	728	1500
CUM FLEET 270	270	1600	1020	1100
CUM FLEET 285	285	1600	1150	1100
CUM FLT 300	300	1700	1150	1100
CUM FORM 240	240	1800	870	1300
CUM FORM 270	270	1800	1000	1300
CUM FORM 300	300	1800	1000	1300
CUM FORM 315	315	1800	1150	1300
CUM FORM 350(90)	350	1800	1175	1300
CUM FORM 350(90)	350	1800	1200	1300
CUM FORM 365(90)	365	1800	1325	1300
CUM FORM 400	400	1800	1250	1300
CUM FORM 450	250	1900	1420	1300
CUM FORM L10-240	240	1400	858	1300
CUM FORM VT-350	300	2100	860	1400
CUM ISX15 400	400	1100	1450	
CUM ISX15 425	425	1100	1650	
CUM ISX15 450	450	1100	1650	
CUM ISX15 485	485	1200	1850	
CUM ISX15 500	500	1200	1850	
CUM ISX15 525	525	1200	1850	
CUM ISX15 550	550	1200	2050	
CUM ISX15 600	600	1200	2050	
CUM KT 450	450	2100	1350	1500
CUM KT 525 (1983)	525	2100	1650	1300
CUM KTA 600 (1983)	600	2100	1650	1600
CUM L10	270	1900	858	1300
CUM L10	300	2100	950	1300
CUM L10 FORM	300	1900	950	1300
CUM L-10 STC 12CGA	260	1600	975	1200
CUM L-10 STC 12CGB	260	1700	975	1200
CUM L-10 STC 12CGC	280	1600	1050	1200
CUM L-10 STC 12CGD	280	1700	1050	1200
CUM L-10 STC 12CGG	310	1600	1150	1200
CUM L-10 STC 12CGH	300	1700	1150	1200
CUM L10-240	240	1900	870	1300
CUM M-11	400	1800	1450	1200
CUM M11 31 OE	310	2000	1150	1200
CUM M11 330E	330	2000	1350	1200

ENGINE HP AND TORQUE RATINGS

NOTE: RATE VARIABLE HORSEPOWER ENGINES TO HIGHEST HORSEPOWER/TORQUE.

ENGINE	HP	@ RPM	TORQUE	@ RPM
CUM M11 370	370	2000	1350	1200
CUM M11ESP11	310-370	1800	1150	1350
CUM M11 280E CELECT	280	2000	1050	1200
CUM N14 12 CEC	370	1600	1400	1200
CUM N14 310	310	1800	1150	1350
CUM N14 330E	330	2100	1350	1200
CUM N14 350E	350	2100	1400	1200
CUM N14 370E	370	2100	1450	1200
CUM N14 410E	410	2100	1450	1200
CUM N14 435E	435	2100	1650	1200
CUM N14 435E	435	2100	1550	1200
CUM N14 469E	460	2100	1650	1200
CUM N14 500	500	1800	1750	1200
CUM N14 500E	500	1750	1650	1600
CUM N14 525	525	1800	1850	1200
CUM N14 CELECT 12 CDB	370	1600	1400	1100
CUM N14 CELECT 12 CDC	430	1700	1450	1100
CUM N14 CELECT 12 CDI	350	1600	1400	1100
CUM N14 CELECT 12 CDJ	460	1700	1450	1100
CUM N14 CELECT 12 CDK	310	1600	1400	1300
CUM N14 CELECT 12 CDR	310	1699	1550	1200
CUM N14 CELECT 12 CDS	330	1600	1250	1100
CUM N14 CELECT 12 CDS	370	1600	1450	1200
CUM N14 CELECT 12 CEN	410	1600	1350	1200
CUM N14 CELECT 12 CEP	430	1700	1550	1300
CUM N14 STC 12 CEE	410	1600	1450	1200
CUM N14 STC 12 CEG	410	1600	1450	1200
CUM N14 STC 12CEH	310	1600	1250	1100
CUM N14 STC 12CEJ	350	1600	1400	1100
CUM N14 STC 12CEK	350	1600	1350	1100
CUM N14EAPI	310-390	1800	1250	1450
CUM N14ESP3	400/460	1800	1450	1650
CUM NHTC-220	220	2100	644	1500
CUM NTC 315	315	1800	1150	1300
CUM NTC 350	350	2100	1120	1300
CUM NTC 365	365	1800	1320	1300
CUM NTC300	300	2100	1000	1300
CUM NTC350(90)	350	2100	1200	1300
CUM NTC400	400	2100	1250	1300
CUM NTC444XT	444	2100	1400	1500
CUM NTC-FORM400	400	1800	1325	1300
CUM PT 240	240	2100	900	1300
CUM SIGNATURE 600	600	2100	2050	1200
CUM STC 12 CEA	330	1600	1350	1100
CUM STC 12 CEB	330	1600	1350	1100

ENGINE HP AND TORQUE RATINGS

NOTE: RATE VARIABLE HORSEPOWER ENGINES TO HIGHEST HORSEPOWER/TORQUE.

ENGINE	HP	@ RPM	TORQUE	@ RPM
CUM TWIN TURBO	475	2100	1430	1400
CUM V-903C	295	2600	1000	1800
DD 11.1 LITER	300	1800	1150	1200
DD 11.11	330	1800	1150	1200
DD 11.11	300-330	1800	1150	1200
DD 11.1L	350	1800	1350	1200
DD 11.1L	365	1800	1350	1200
DD 11.L	330	1800	1250	1200
DD 11.L	220-365	1800	1350	1200
DD 11.L	330-350	1800	1350	1200
DD 12.71	500	1800	1550	1200
DD 12.72	500	2100	1550	1200
DD 12.7L	350	2100	1400	1200
DD 12.7L	370	2100	1450	1200
DD 12.7L	400	2100	1450	1200
DD 12.7L	470	2100	1550	1200
DD 12.7L	370/400	1800	1450	1200
DD 12.7L	370/430	1800	1450	1200
DD 12.7L	430/470	1800	1550	1200
DD 12/7L	425	2100	1400	1200
DD 12/7L	430	1800	1450	1200
DD 12/7L	430	2100	1550	1200
DD 12/7L	435	1800	1550	1650
DD 13	350	1800	1350	
DD 13	370	1800	1250	
DD 13	380	1800	1550	
DD 13	410	1800	1650	
DD 13	435	1800	1550	
DD 13	450	1800	1650	
DD 13	470	1800	1650	
DD 15	530	1800	1850	
DD 15	560	1800	1850	
DD 15	455	1800	1650	
DD 15	475	1800	1850	
DD 15	500	1800	1850	
DD 15	505	1800	1650	
DD 15 TC	455	1800	1650	
DD 15 TC	475	1800	1850	
DD 15 TC	505	1800	1860	
DD 16	475	1800	1850	
DD 16	500	1800	2050	
DD 16	530	1800	1850	
DD 16	560	1800	2050	
DD 16	600	1800	2050	
DD 6-71	230	2100	611	1600

ENGINE HP AND TORQUE RATINGS

NOTE: RATE VARIABLE HORSEPOWER ENGINES TO HIGHEST HORSEPOWER/TORQUE.

ENGINE	HP	@ RPM	TORQUE	@ RPM
DD 6-71T	275	2100	853	1200
DD 6-71T	300	2100	830	1400
DD 6-71TAC	270	2100	786	1200
DD 6V92TA	330	2100	963	1200
DD 6V92TA	350	2100	1020	1200
DD 8V71	304	2100	818	1400
DD 8V92TA	400	1800	1250	1200
DD 8V92TA	445	2100	1250	1300
DD 8V92TA	475	2100	1330	1300
DD 8V92TAC	440	2100	1250	1300
DD HAL	250	1800	970	1200
DD SERIES 60 11.1L-1L-6	330	1800	1150	1200
DD SERIES 50 8.5L-1 L-4	275	2100	890	1200
DD SERIES 50 8.5L-1L-4	300	1800/2100	1000	1200
DD SERIES 50 8.5L-1L-4L	315	1950/2100	1150	1200
DD SERIES 50 8.5L-1L-4	250	2100	780	1200
DD SERIES 55 12.1-1L-6	330	1800/2000	1250	1100
DD SERIES 55 12.1-1L-6	330/350	1800	1350	1100
DD SERIES 55 121-1L-6	350	1800/2000	1350	1100
DD SERIES 55 12L-1L-6	300	1800	1150	1100
DD SERIES 55 12L-1L-6	365	1800/2000	1450	1100
DD SERIES 55 12L-1L-6	365/400	1800	1450	1100
DD SERIES 60 11.1 L-1L-6	330/365	1800	1350	1200
DD SERIES 60 11.1-1L-6	350	1800	1250	1200
DD SERIES 60 11.1L-1L-6	300	1800	1150	1200
DD SERIES 60 11.1L-1L-6	330	1800	1150	1200
DD SERIES 60 11.1L-1L-6	350	2100	1250	1200
DD SERIES 60 11.1L-1L-6	365	1800	1350	1200
DD SERIES 60 11.1L-1L-6	300/330	1800	1150	1200
DD SERIES 60 11.1L-1L-6	330/350	1800	1250	1200
DD SERIES 60 12.7-1L-6	400	2100	1450	1200
DD SERIES 60 12.7-1L-6	370/400	1800	1450	1200
DD SERIES 60 12.7L-1 L-6	430	2100	1450	1200
DD SERIES 60 12.7L-1 L-6	500	1800	1550	1200
DD SERIES 60 12.7L-1 L-6	370/430	2100	1450	1200
DD SERIES 60 12.7L-1 L-6	430/470	2100	1550	1200
DD SERIES 60 12.7L-1L-6	370	2100	1450	1200
DD SERIES 60 12.7L-1L-6	470	1800	1550	1200
DD SERIES 92 12.11-V8	400	2100	1330	1200
DD SERIES 92 12.1L-V8	500	2100	1470	1200
DD SERIES 92 12.1L-V-8	450	2100	1425	1200
DD SERIES 92 9.051-V-6	350	2100	1020	1200
DD SERIES 92 9.05L-V6	300	2100	975	1200
FD-1060	160	2500	400	1600
FD-1060	175	2500	420	1600

ENGINE HP AND TORQUE RATINGS

NOTE: RATE VARIABLE HORSEPOWER ENGINES TO HIGHEST HORSEPOWER/TORQUE.

ENGINE	HP	@ RPM	TORQUE	@ RPM
FD-1060	190	2500	475	1600
FD-1060	210	2300	520	1600
FD-1060	230	2300	605	1600
FD-1460	210	2200	605	1300
FD-1460	225	2200	660	1300
FD-1460	250	2000	800	1300
FD-1460	275	1800	860	1300
FORD 7.3 HI. ALT.	165	3000	325	1600
FORD 7.3L NATASP	185	3000	360	1400
FORD 7.3L TURBO	190	3000	395	1400
GM 6.5 L NATASP	160	3400	290	1700
GM 6.5 L TURBO	190	3400	385	1700
GM 6.5L NATASP	155	3600	275	1700
GM 6.5L TURBO	180	3400	360	1700
INTL 530	250	2200	800	1300
INTL 530	275	2000	950	1300
INTL 530	275	2200	860	1300
INTL 530	300	2000	1050	1300
INTL DT 408	210	2600	520	1800
INTL DT 408	230	2600	605	1800
INTL DT 466	195	2400	520	1600
INTL DT 466	210	2400	605	1600
INTL DT 466	275	2400	800	1600
INTL DT-408	175	2600	430	1800
INTL DT-408	190	2600	485	1800
INTL DT-466	230	2400	660	1600
INTL DT-466	250	2400	660	1600
INTL T444E	160	2600	400	1500
INTL T444E	175	2600	430	1500
INTL T444E	190	2600	485	1500
L10	280	1800	1050	1200
L-10 240/250PT	240-2100	250-2200	900	1300
L10 285PT	285	2200	1020	1300
L-10 FORM 240	240	1900	860	1300
M11 ESP1	280-330	1800	1050-1250	1200
M11-280E	280	2000	1050	1200
M11350E	350	1800	1350	1200
MACK E3-190 (MECH) CAT	190	2500	475	1300
MACK E3-220 (MECH)	220	2350	627	1400
MACK E6-250	250	2100	750	1500
MACK E6-275	275	2100	1020	1200
MACK E-6-300	300	1700	1112	1200
MACK E6-350	350	1800	1277	1250
MACK E7 325 VMAC	325	1800	1260	1250
MACK E7 350 VMAC	350	1800	1250	1250

ENGINE HP AND TORQUE RATINGS

NOTE: RATE VARIABLE HORSEPOWER ENGINES TO HIGHEST HORSEPOWER/TORQUE.

ENGINE	HP	@ RPM	TORQUE	@ RPM
MACK E7 375 VMAC	375	1800	1460	1250
MACK E7 400	400	1800	1460	1250
MACK E7 427	427	1800	1560	1250
MACK E-7 454	454	1800	1560	1250
MACK E7-250 (MECH)	250	1950	975	1200
MACK E7-300 (MECH)	300	1950	1083	1200
MACK E7-300 (V MAC)	300	1700	1160	1200
MACK E7-350	350	1800	1277	1250
MACK E9	550	2100	1660	1300
MACK E9 450	450	1900	1495	1300
MACK E9 500	500	1900	1660	1300
MACK EM6-250	250	2100	940	1260
MACK EM6-250L	250	1750	1190	1020
MACK EM6-275	275	2100	1038	1260
MACK EM6-275L	275	1750	1305	1020
MACK EM6-300L	300	1750	1425	1020
MACK EM7-250 (MECH)	250	1750	1190	1020
MACK EM7-250L	250	1750	1190	1020
MACK EM7-275 (MECH)	275	1750	1305	1250
MACK EM7-275 (V MAC)	275	1750	1305	1250
MACK EM7-300 (MECH)	300	1750	1425	1020
MACK EM7-300VMAC	300	1750	1425	1020
MBE 4000-350	350	1900	1350	
MBE 4000-350/370	350/370	1900	1350	
MBE 4000-370	370	1900	1450	
MBE 4000-410	410	1900	1550	
MBE 4000-410/435	410/435	1900	1550	
MBE 4000-410/450	410/50	1900	1550	
MBE 4000-435	435	1900	1550	
MBE 4000-450	450	1900	1550	
MX-13	380	1000	1450	
MX-13	405	1000	1750	
MX-13	430	1000	1750	
MX-13	455	1000	1750	
MX-13	485	1000	1650	
MX-13	500	1000	1850	
N 14ESPII	350-390	1800	1350	1500
NTC 475	475	2100	1430	1400
VOLVO 260E/300AE	260	2100	800	1080
VOLVO 280G/330BE	280	1700	925	1200
VOLVO 300A/360CE	300	2100	925	1200
VOLVO 300CC/410DE	300	2100	955	1200
VOLVO 310B	310	1900	985	1200

CROSS-REFERENCE

MEDIUM-DUTY CROSS-REFERENCE

ROAD CHOICE	EATON ADVANTAGE	EATON EVERTOUGH	EATON REMAN	MERITOR ALL FIT	TRP	ALLIANCE	IATCO
CLU1072374				MAF-107237-4CB			
CLU10723710		107237-10, 107237-22		MAF-107237-22	CL107337-10	ABP N25 14860ST	NMU060-022-5-A
CLU1076834				MAF-107683-4			NMU059-024-6
CLU1076835		107683-5		MAF-107683-5	CL107783-5	ABP N25 14620SB	NMU059-022-1
CLU10734212		107342-12		MAF-107342-12	CL107442-12	ABP N25 14860SB	NMU061-092-5-A
CLU1076864				MAF-107342-24			NMU061-023-3-A

HEAVY-DUTY 14" (POT STYLE) CROSS-REFERENCE

ROAD CHOICE	EATON ADVANTAGE	EATON EVERTOUGH	EATON REMAN	MERITOR ALL FIT	TRP	ALLIANCE	IATCO
CLU10805060				MAF-108035-82B			NMU800-020-4
CLU10805059	108050-59B	108050-59AM	108050-59MO	MAF-108050-59B	CL108150-59	ABP N25 141400SB, ABP N25 108050 59	NMU890-184-1
CLU10806359				MAF-108063-59A			NMU800-084-1

HEAVY-DUTY 15.5" EZ PEDAL CROSS-REFERENCE

ROAD CHOICE	EATON ADVANTAGE	EATON EVERTOUGH	EATON REMAN	MERITOR ALL FIT	TRP	ALLIANCE	IATCO
CLU20839174		108391-74AM	108034-61MO	MAF-108391-74		ABP N25 1551650EZ, ABP N25 1551650EZCO, ABP N25 208925 74	NMU898-064-4
CLU20839181		108391-81AM	108391-81MO	MAF-108391-81	CL108291-81	ABP N25 1551400EZCO, ABP N25 108391 81	NMU898-094-4
CLU20839193				MAF-108391-93			NMU898-067-6
CLU20839193H				MAF-108391-93H		ABP N25 108391 93	NMU898-067-8
CLU20892582	208925-82, 208925-85, 308925-82, 308925-82	108925-82AM	108935-82MO	MAF-108925-82	CL108825-82	ABP N25 1551700EZ, ABP N25 208925 82	NMU898-044-4

HEAVY-DUTY 15.5" SELF-ADJUST CROSS-REFERENCE

ROAD CHOICE	EATON ADVANTAGE	EATON EVERTOUGH	EATON REMAN	MERITOR ALL FIT	TRP	ALLIANCE	IATCO
CLU20992582	209701-82, 309701-82	109701-82AM	109700-82MO	MAF-209925-82		ABP N25 209701 82	NMU701-044-4
CLU20992582H	209701-20, 209701-25, 309701-20, 309701-25	109701-20AM/109701- 25AM	109700-20MO	MAF-209925-25		ABP N25 209701 25	NMU701-207-6, NMU701-147-6
CLU20993551	209701-51,309701-51	109701-51AM		MAF-209935-51			NMU701-054-4-M
CLU20993551H	209701-61, 209701-91, 20970192, 309701-68, 309701-91, 309701-98	109701-92AM	109700-61MO	MAF-209935-51H		ABP N25 209701 94, ABP N25 209701 91	NMU701-057-4-M, NMU701-057-6-M
CLU12200235A	122002-35A						
CLU12200342A	122003-42A						

HEAVY-DUTY STANDARD PEDAL CROSS-REFERENCE

ROAD CHOICE	EATON ADVANTAGE	EATON EVERTOUGH	EATON REMAN	MERITOR ALL FIT	TRP	ALLIANCE	IATCO
CLU10739007							NMU597-090-4
CLU10739080							

TOP 10 SELLING

CLUTCHES

RATING	PART NUMBER	DESCRIPTION
1	CLU20892582	15.5" X 2" 7SPR 1700 TRQ
2	CLU20892582H	15.5" x 2" 7 SPR 2050 TRQ
3	CLU20893551	15.5" x 2" 9 SPR 1700 TRQ
4	CLU20893551H	15.5" x 2" 9 SPR 2050 TRQ
5	CLU20839174	15.5" x 2" 10 SPR 1650 TRQ
6	CLU20892525	15.5" x 2" 7 SPR 2050 TRQ
7	CLU20992582	15.5" x 2" 7 SPR 1700 TRQ Self-Adjust
8	CLU20992582H	15.5" x 2" 7 SPR 2050 TRQ Self-Adjust
9	CLU20993551	15.5" x 2" 9 SPR 1700 TRQ Self-Adjust
10	CLU20993551H	15.5" x 2" 9 SPR 2050 TRQ Self-Adjust

FLYWHEELS

RATING	PART NUMBER	DESCRIPTION
1	FLY530GB3170	15" Flat Mack E-Tech
2	FLY530GB3145BM	15" Cummins L10/M11
3	FLY530GB3142	15" Flat Mack 675/676
4	FLY1818214C91	14" Flat 7.3 444E
5	FLY1821915C91	14" Flat DT466
6	FLY23509709	15" Detroit Series 60
7	FLY1265875	14" Flat CAT 3116/3126
8	FLY1810855C93	14" Flat DT 466
9	FLY3921263	14" Flat Cummins 5.9B
10	FLY3042787	14" POT Cummins NT855

ACCESSORIES

RATING	PART NUMBER	DESCRIPTION
1	CLA127200	2" 2-Piece Hinged Clutch Brake
2	CLA1272005	2" Oversized Hinged Clutch Brake
3	CLA127760	2" Torque-Limiting Clutch Brake
4	CLA6306V	Viton® Bearing 6306
5	CLAK2468	Major Install Kit
6	CLAK2200	2" Minor Clutch Kit
7	CLA6306M	Pilot Bearing with Snap Ring (Mack)
8	CLA6306	Pilot Bearing
9	CLAK2175	1.75" Minor Clutch Kit
10	CLA6306VM	Viton® Bearing (Mack)



ROAD CHOICE

© 2024 Road Choice® – All Rights Reserved.
RCOCL-24CAT-081424